

Teslakala.com

**China Technical Service Headquarter**  
**Manufacturer: Shanghai Sanyu Industry Co.,Ltd.**  
**Address: Room 723, No.800 Shangcheng Road, Shanghai, China**  
**Tel: +86-21-65046976**  
**Fax: +86-21-51686158**  
**Postal code: 200120**  
**Website: [www.sanyuacdrive.com](http://www.sanyuacdrive.com)**  
**E-Mail: [alansunrise@sina.com](mailto:alansunrise@sina.com)   [sales@sanyuinverter.com](mailto:sales@sanyuinverter.com)**

**The technical parameters are subject to change without notices.**  
**All rights reserved.**  
**Figures herein are for information only.**



**Instruction Manual  
of  
SJR2-3000 Series**

**Micro-power Motor Soft Starter with Inbuilt Bypass**



**Sanyu, control and protect your motors**

**Shanghai**

**Sanyu**

**Industry**

**Co.,Ltd.**

1. Matters before using.....	1
1-1 Product overview.....	1
1-2 Operation instructions.....	1
1-3 Receiving inspection.....	2
1-4 Product appearance.....	2
2. Service conditions and installation requirements.....	3
2-1 Service conditions of the soft starter.....	3
2-2 Installation requirements of the soft starter.....	3
2-3 Connection .....	4
2-4 Connection of main circuit and grounding terminal.....	5
2-5 Connection diagram for main circuit of SJR2-3000 soft starter.....	6
2-6 Connection of control terminals.....	7
2-7 Terminal configuration diagrams.....	8
2-8 Primary and secondary connection diagram of SJR2-3000 series (three-wire mode).....	9
2-Primary and secondary connection diagram of SJR2-3000 series (two-wire mode).....	9
3. Running.....	10
3-1 Inspection and preparation before running.....	10
3-2 Running method.....	10
4. The keyboard panel.....	11
4-1 External of the keyboard panel.....	11
5. Basic functions.....	12
5-1 Code setting function.....	12
6. Detailed description of function selection .....	13
7. Operation steps.....	14
7-1 Modify the set parameters.....	14
8. Help information.....	15
8-1 Description of help information.....	15
9. Protection function.....	15
9-1 Description of protection function.....	15
9-2 Setting of protection function.....	16
9-3 Protective tripping curve.....	17

10. Operated protection.....	18
10-1List of protective actions.....	18
11. Troubleshooting.....	19
11-1Problems and solutions.....	19
12. Starting mode.....	20
12-1 Current limiting starting mode.....	20
12-2Voltage ramp starting mode.....	20
12-3 Kick Mode.....	21
12-4 Current ramp starting mode.....	21
12-5 Voltage and current limiting double closed-loop starting.....	22
12-6 Soft stop.....	22
12-7 Free stop.....	22
13. External dimensions.....	23
13-1 External dimensions of 5.5kw~75kw.....	23
13-2 External dimensions of 75kw~400kw.....	24
14. Application range.....	25
14-1Types of application load.....	25
15. RS485 communication.....	25
15-1MODBUS communication protocols.....	25
15-2 Relevant settings of the soft starter.....	26
15-3 Exception response.....	28
15-4 Notes for use.....	28
16. Annex.....	30

## 1. Matters before Using

### 1-1 Product overview

Thanks for purchasing the “SJR2-3000” series online micro-power consumption motor soft starter of Shanghai SANYU. The company has made further technical improvement in both the software and the structure of the soft starter according to the market demand. With inbuilt bypass contactor the soft starter provides complete motor protection functions including start control, running and overloading, phase failure, three-phase unbalance, over-voltage, under-voltage protection and so on with no need to further install bypass contactor and thermal relay, therefore, as another great achievement in the intelligentization of motor protection and networked technology application, it simplifies the circuit, reduces the volume, cuts the cost, makes installation and using more convenient.

### 1-2 Operation instructions



Be sure to read the operation instructions carefully before installation.



The soft starter must be installed by professionals.



The specifications of motor must match with the soft starter.



Do not connect capacitor to the output terminals (U V W) of the soft starter.



The exposed connection terminals must be wrapped with insulating tape.



The soft starter and other relevant equipments should be reliably grounded.



The input power must be cut off during equipment maintenance.



Do not disassemble, modify or repair the product privately.

**1-3 Receiving inspection**

Upon receiving the equipment you purchased, please unpack to inspect the following items, in the event that there's any problem with the product or the product is not in consistent with the specifications you purchased, please contact with the agent from whom you purchased the equipment or the nearest office of our company.

- 1) Check the name plate in the soft starter and confirm the specifications you purchased.

**Specifications name plate**

<p><b>SJR2-3000 Series Motor Soft Starter</b>                  Model: SJR2-3075                  Input voltage: AC380V 50Hz                  Rated operational current:150A                  Manufacturing number:                  Manufacturing date:                  Shanghai Sanyu Industry Co.,Ltd.</p>
---------------------------------------------------------------------------------------------------------------------------------------------------------------------------------------------------------------------------------------------------------------------------------------------------------------------------------------

**Model of the soft starter**

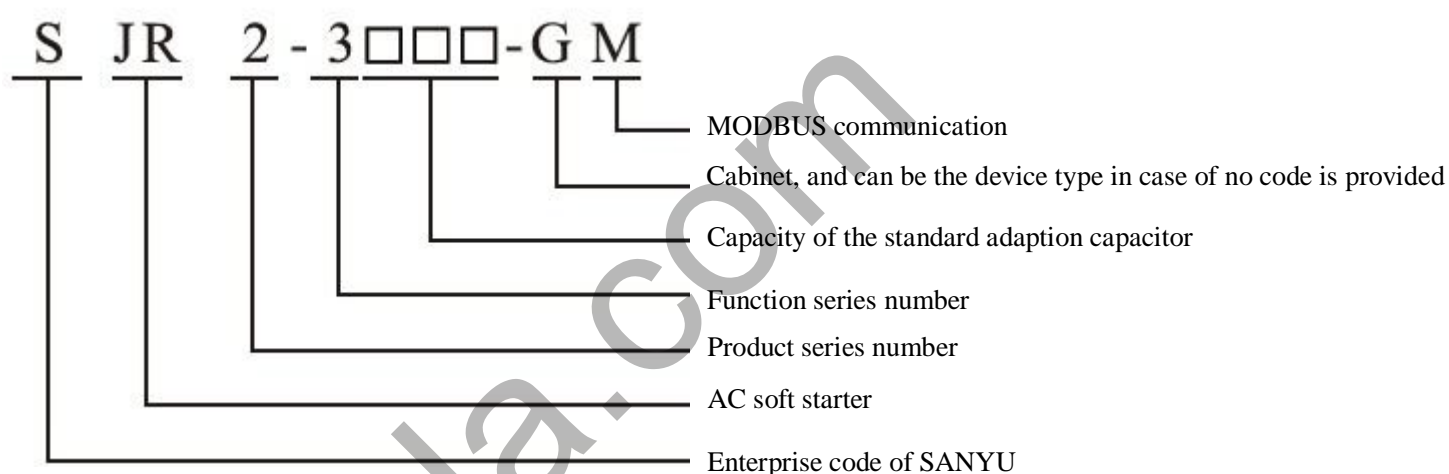

- 2) Check for damages during transportation, such as bending of the cover and the enclosure, damage or missing of parts and components and so on;
- 3) An operation instruction and a compliance certificate shall be attached with the soft starter.
- 4) When moving the soft starter, lift its frame instead of the circuit board control box otherwise falling damage or personal injury may be caused.

**1-4Product appearance**

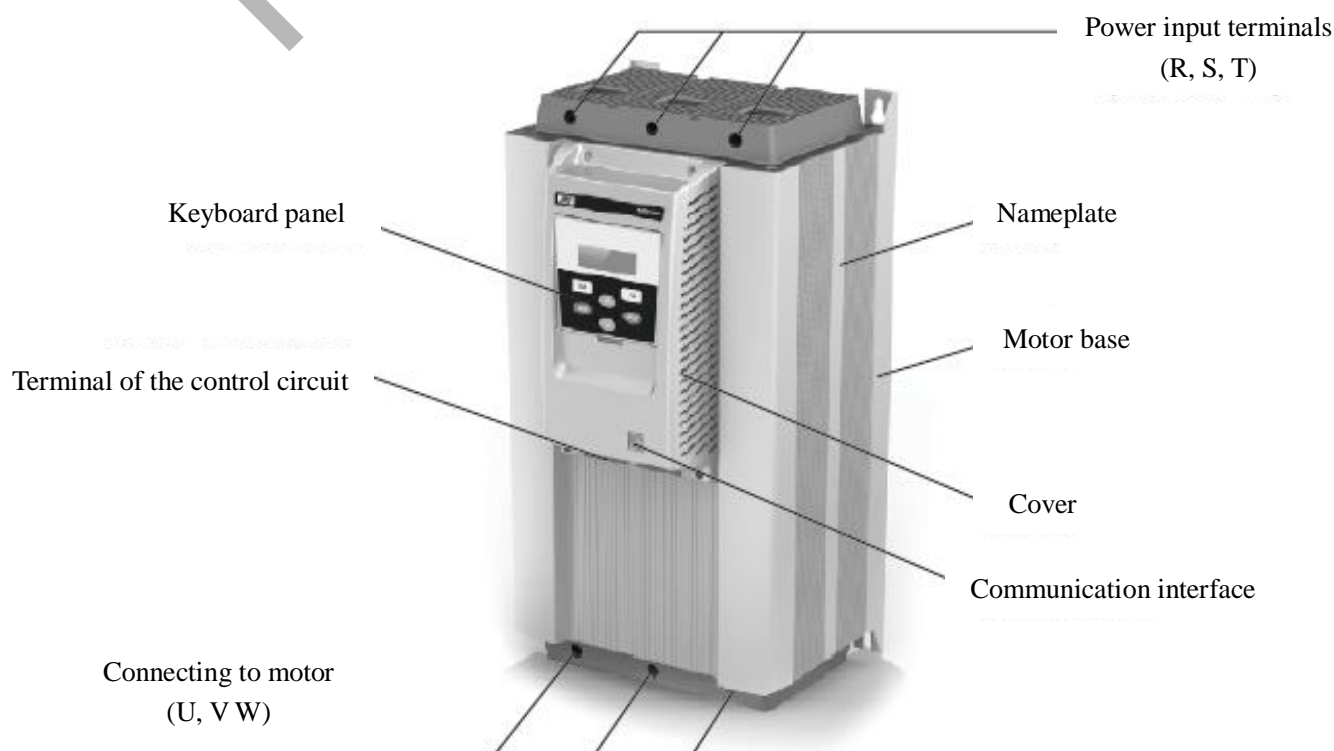

## 2. Service conditions and installation requirements

For SJR2-3000 series soft starter, the following service conditions and installation requirements should be followed, otherwise, the performance shall not be ensured, and in severe cases, the life-loss or even damage of the soft starter will be caused.

### 2.1 Service conditions of the soft starter:

Power supply: three-phase AC 380V or 660V±15%, 50 Hz or 60 Hz commercial power, private power station or diesel generator set , the power capacity must meet the soft starter’s starting requirements on motor.

Applicable motor: three phase squirrel-cage asynchronous motor, the rated power of the motor should match that of the soft starter.

Start frequency: no requirements, the specific frequency shall be depended on the loading.

Cooling method: natural air cooling.

Protection class: IP20

Environmental conditions: the place with elevation below 3000m, ambient temperature between-25°C~+40°C, relative humidity under 90%, no condensation, no flammable, explosive, corrosive gas, no conductive dirt, good ventilation and vibration less than 0.5G.

**The company can provide customers with products to be used under special conditions, such as explosion proof type, low temperature type and high pressure type soft starters, service conditions of such starters shall be otherwise indicated.**

### 2.2 Installation requirements of the soft starter:

Installation direction and space: to enable good ventilation and heat dissipating conditions during using of the soft starter, the soft starter should be installed vertically with enough space for heat dissipating left around the equipment. The allowable minimum spaces are shown in figure 2.1 and figure2.2.

In the event that the soft starter is installed inside the cabinet, besides the above requirements, the cabinet selected should be with good ventilation at the top and bottom, as shown in figure 2.3.

Unit: mm



Figure 2.1



Figure 2.2

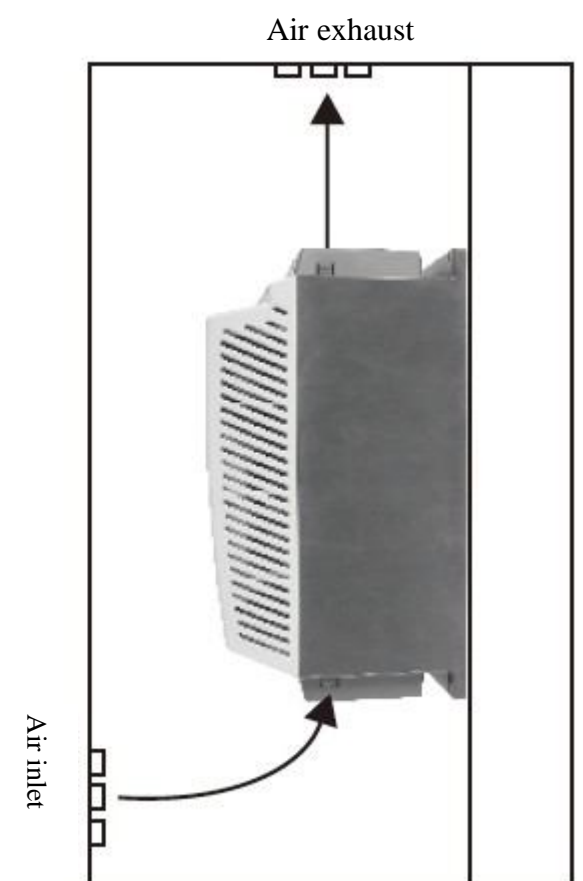

Figure 2.3

**2-3 Connection**

Be sure to note all the following instructions during connection. Figure 2-3-1 shows the basic connection.

- a) The power must be connected to the R, S, T power terminals of the main circuit with no requirements in phase sequence. The soft starter will be damaged if the power is mis-connected.
- b) The grounding terminal must be reliably grounded, as it will prevent electric shock or fire alarm accidents as well as reduce noise.
- c) Crimping should be conducted at both ends of the wire to ensure high reliability of connection.

**Basic connection diagram**

Figure 2-3-1

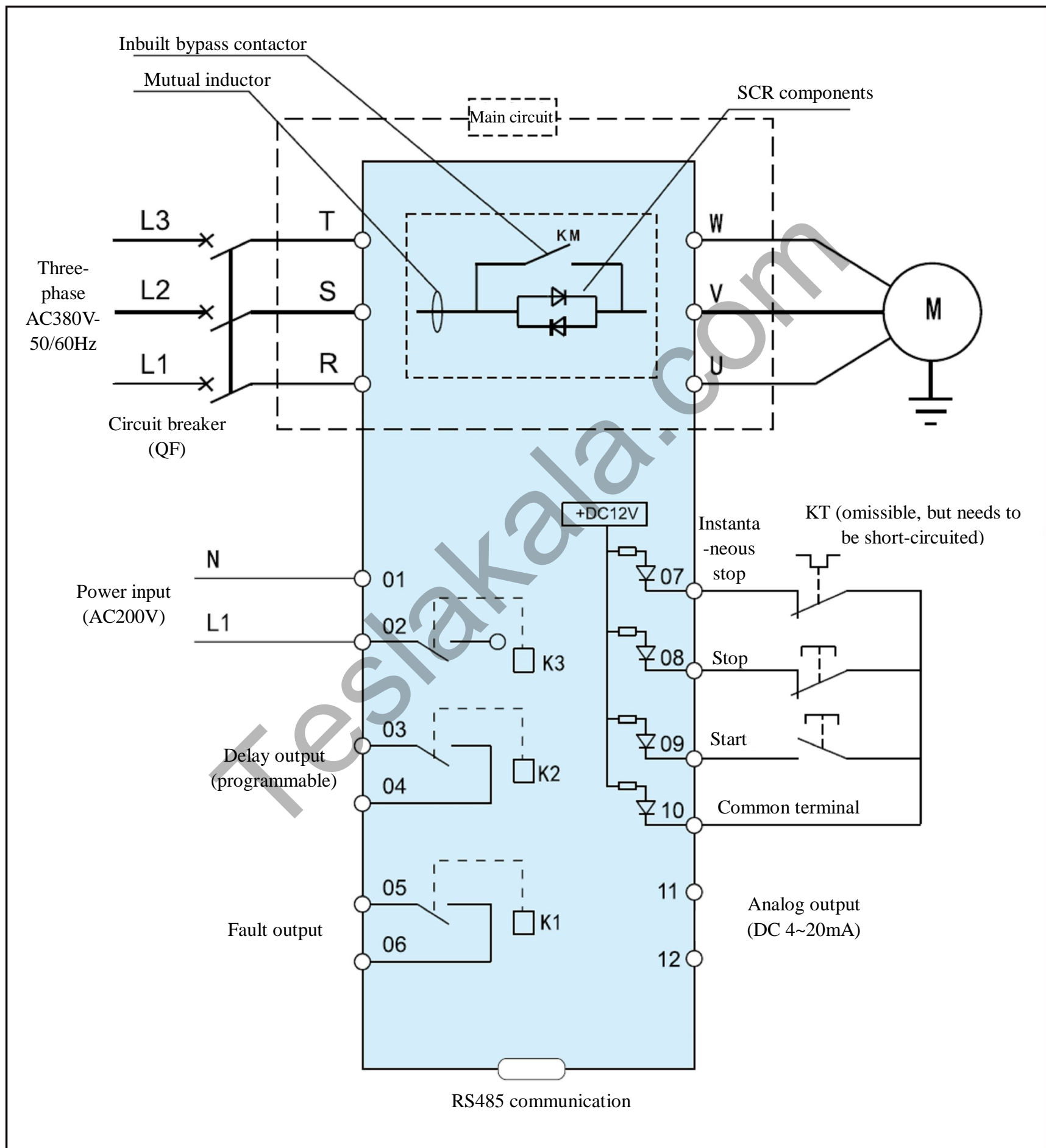



**2-4 Connection of the main circuit and the grounding terminal**

Table 2-4-1 Functions of the main circuit and the grounding terminal

Terminal markings	Terminal description	Remarks
R,S,T	Input of the main circuit power	Connecting three-phase power
U,V,W	Output connection of the soft starter	Connecting three-phase motor
 G	Grounding of the soft starter	Grounding terminal of the soft starter cabinet should be reliably grounded.

(1) Main circuit power input terminal (R,S,T)

- a. Connect the main circuit input terminals R, S, T to the three-phase AC power through the circuit breaker for circuit protection or circuit breaker with leakage protection without considering the connection sequence.
- b. Do not use ON/OFF of the main circuit power to control running and stop of the soft starter, instead, such should be controlled by means of the control terminal or RUN and STOP buttons in the keyboard panel of the soft starter upon power on.
- c. Do not connect the soft starter to the single-phase power.

(2) Output terminals of the soft starter (U,V,W)

- a. Output terminals of the soft starter should be connected to the three-phase motor in correct phase sequence. If the rotation direction of the motor is incorrect, switch connection of any two phases among U, V and W.
- b. The output end of the soft starter shall not be connected to capacitor or surge absorber.
- c. If the wire between the soft starter and the motor is very long, the distributed capacitance between the wires will generate high-frequency current which may cause over-current tripping, leakage current increasing and poor current display precision of the soft starter. Therefore, it is suggested that the motor connection wire should be no more than 50m.

(3) Grounding terminal of the soft starter ( G)

- a. For safety and noise reducing, the grounding terminal G of the soft starter must be well-grounded. To prevent electric shock and fire accidents, the metal enclosure and frame of the electric equipment should comply with the requirements of the national electronic procedures.

 Danger!	Confirm the input number of phases of the soft starter. The rated input voltage value should match the number of phases and voltage value of the AC power. The AC power shall not be connected to the output terminals (U, V, W), otherwise damages may be caused.
------------------------------------------------------------------------------------------------	--------------------------------------------------------------------------------------------------------------------------------------------------------------------------------------------------------------------------------------------------------------------

**2-5 Connection diagram for main circuit of SJR2-3000 soft starter**

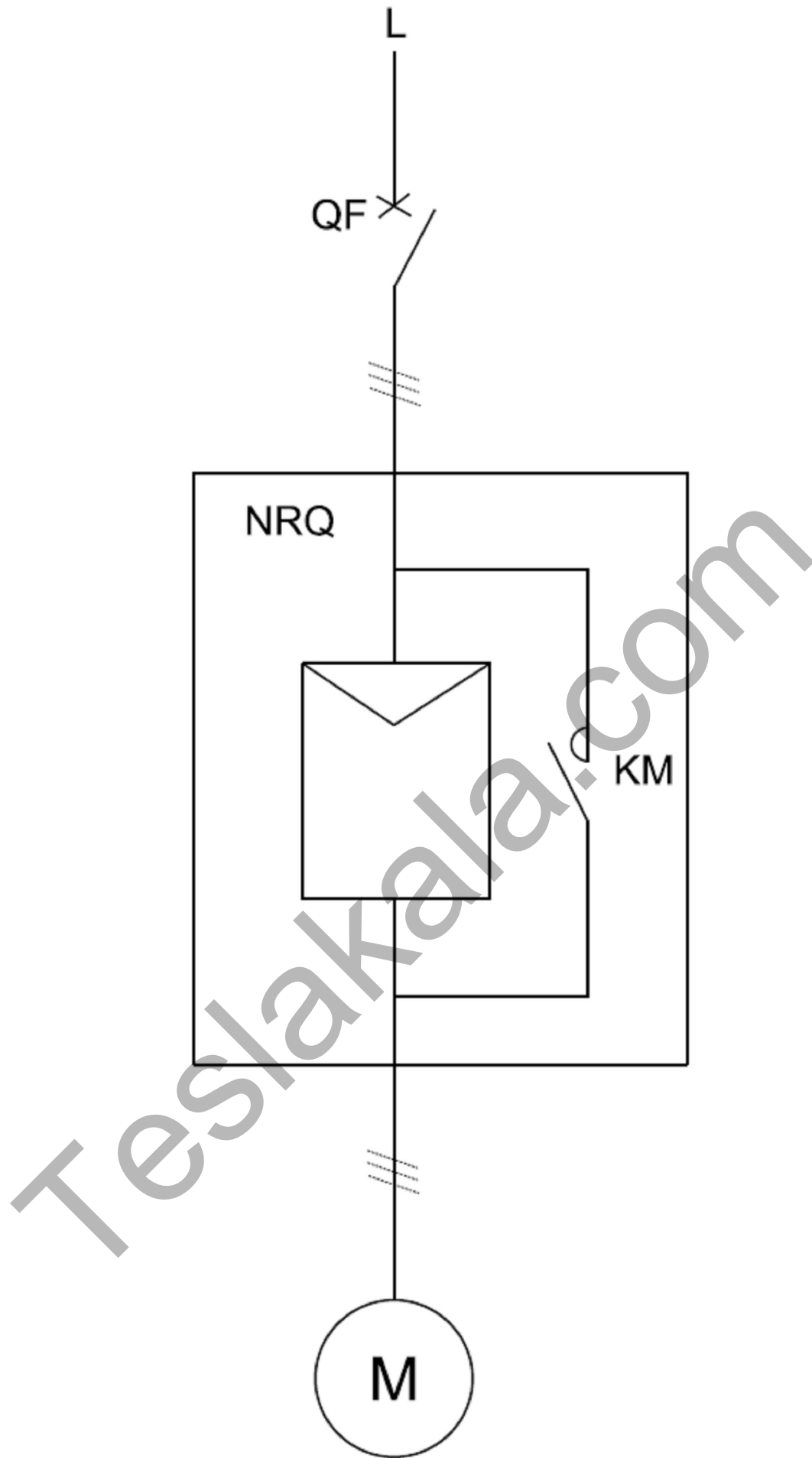

**QF circuit breaker**

**NRQ soft starter with inbuilt bypass**

**M motor**

**KM contactor installed inside the soft starter with inbuilt bypass**

## 2-6 Connection of control terminals

Functions of the control circuit terminals are shown in table 2-6-1. Functions and connection of different control terminals vary with different function settings.

Table2-6-1

Classification	Terminal marking	Terminal description	Function description
Connection point output	01, 02	Power input	01, 02 are AC220V power input to the control panel
	03, 04	Running output (delay)	03, 04 are programmable relay output, the delay time is set by the code F4 while the output function time is set by code FE.
	05, 06	Fault output	005, 06 are fault relay output, they will be on when there's fault with the soft starter or the power is cut off and be off when the power is on. (capacity of the connection point AC250V/3A)
Connection point input	07	Instantaneous stop input	The motor will stop immediately when 07 and 10 are disconnected (or be tandemly connected to the normally closed point of the thermal relay)
	08	Soft stop input	The motor will slow down for soft stop when 08 and 10 are disconnected (or automatically stop).
	09	Start input	The motor will start for running when 09 and 10 are connected.
	10	Common terminal	Common terminal for signal input of the connection points
Analog output	11, 12	Analog output	11 and 12 are 4~20mA DC analog output which are used to monitor the current of the motor in real time. The maximum value 20mA indicates the current of the motor is four times of the nominal current of the soft starter. 4~20mA DC meter can be connected for observation. Maximum load resistance of this output is 300Ω.
Communication	DB	RS485communication input/output	Input and output signal terminal of RS485 communication, can be used to connect several soft starters.

### (1) Input terminals of the connection point

- a) Please set code FB to be external-control valid when the external terminals are used to control the start and stop functions of the soft starter.
- b) Please use (two-wire) control mode when remote control is required, see P9: figure 2-9.
- c) The signal input terminals and common terminal of the connection points are generally operated for ON/OFF, since the soft starter, the motor and wiring will cause interference, therefore, it is suggested to arrange shorter wire (no more than 20m) and use shielded wire as the cable.
- d) Wiring of the control terminals should be kept away from that of the main circuit to the extent possible; otherwise, malfunction may be caused by the interference.

**2-7 Terminal configuration diagrams**

Terminal diagram of the main circuit

(1) SJR2-3005.5~3075

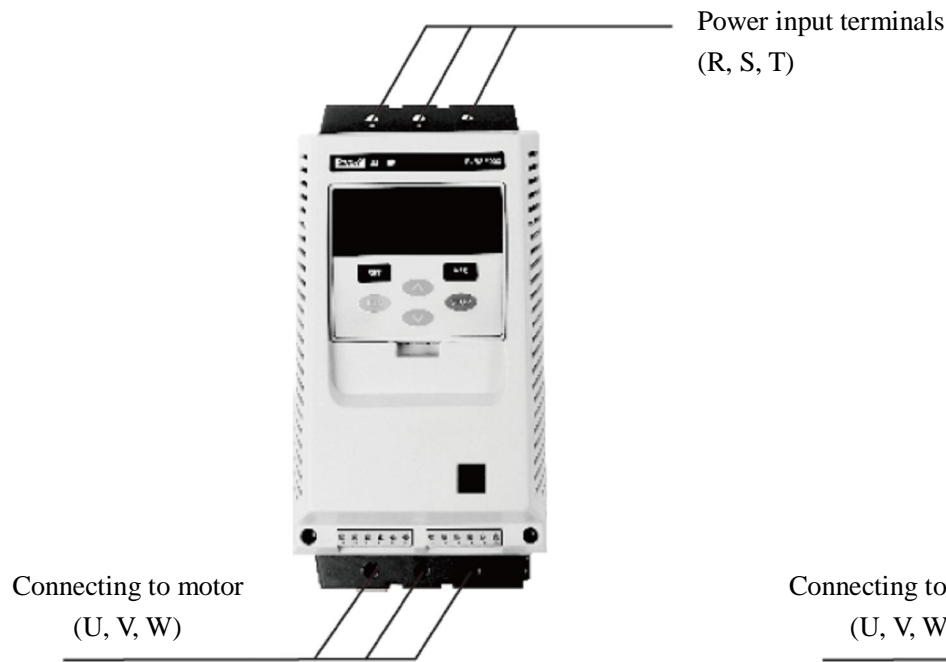

SJR2-3075~3400

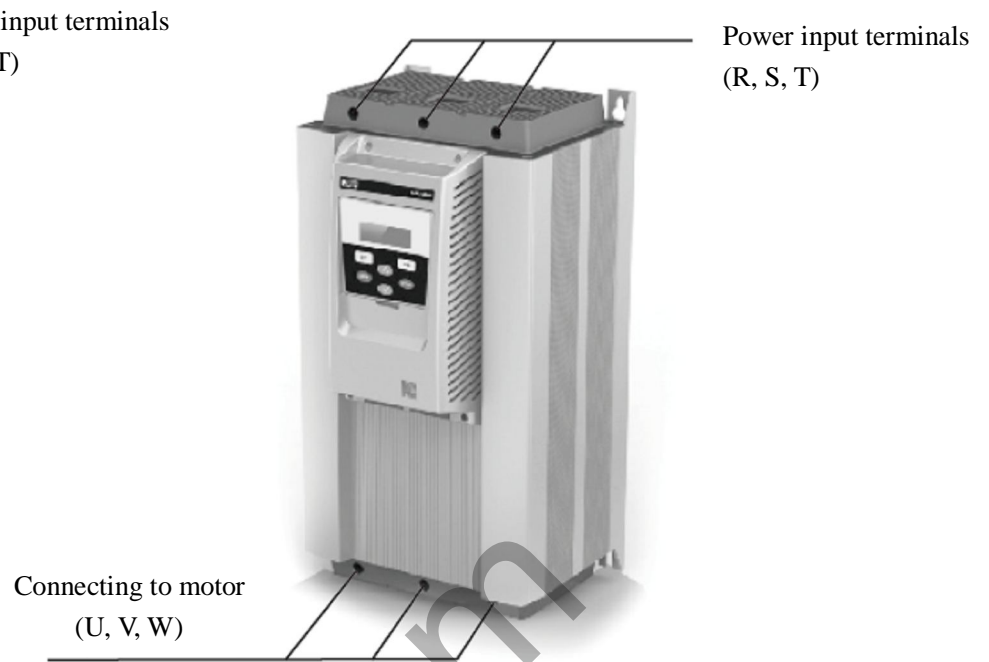

(2) Terminal diagram of the control circuit

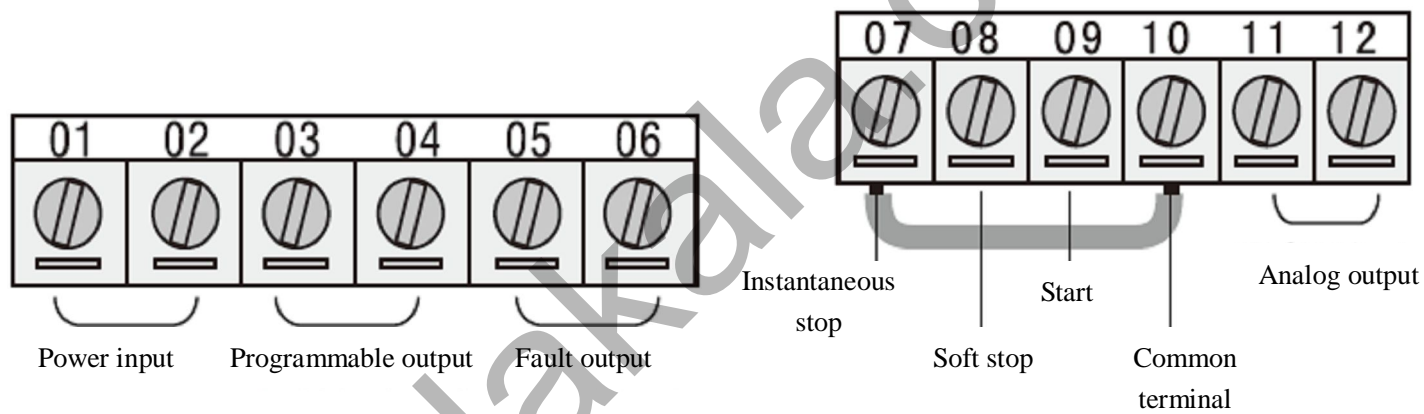

(3) Terminal connection of the control circuit

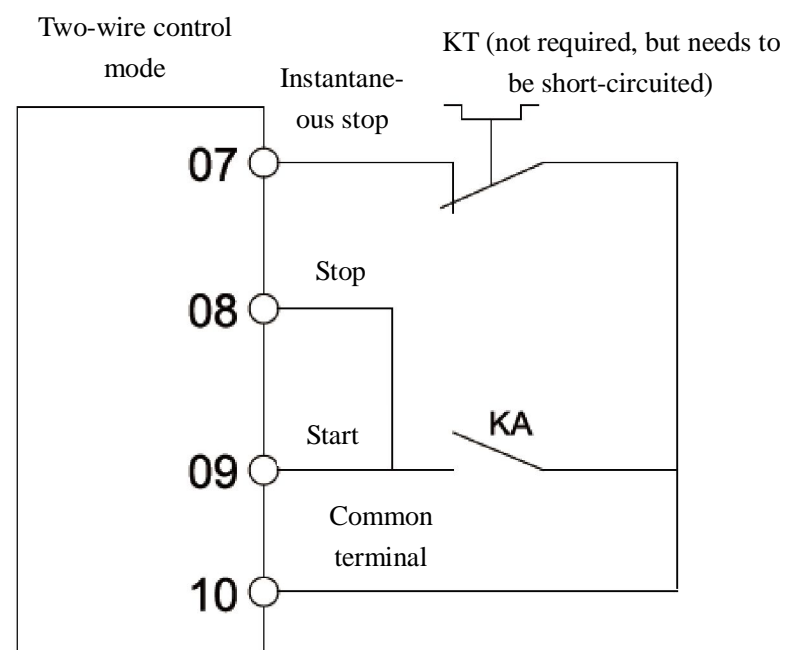
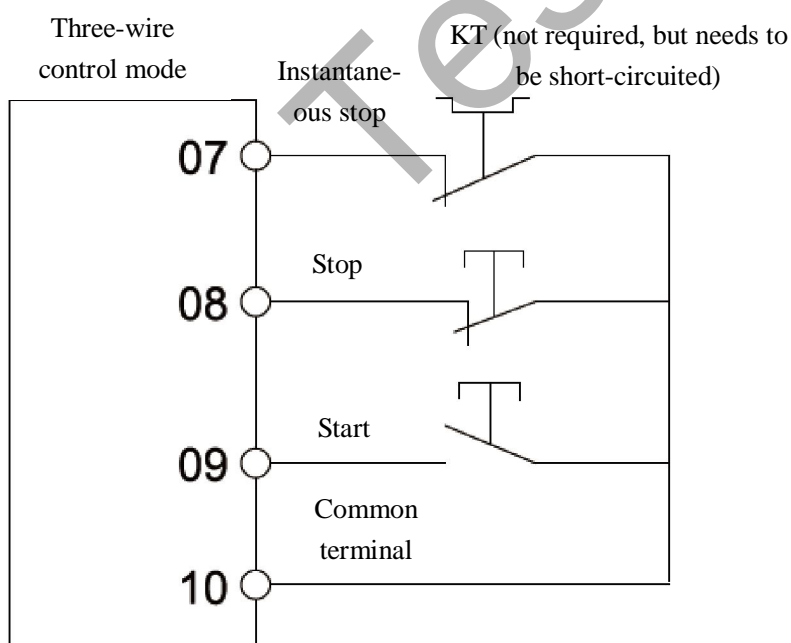

Wire of the control terminals should be 0.75~1.25mm<sup>2</sup>

Soft starter will start for running when KA is connected and stop when KA is disconnected.

2-8 Terminal configuration diagrams

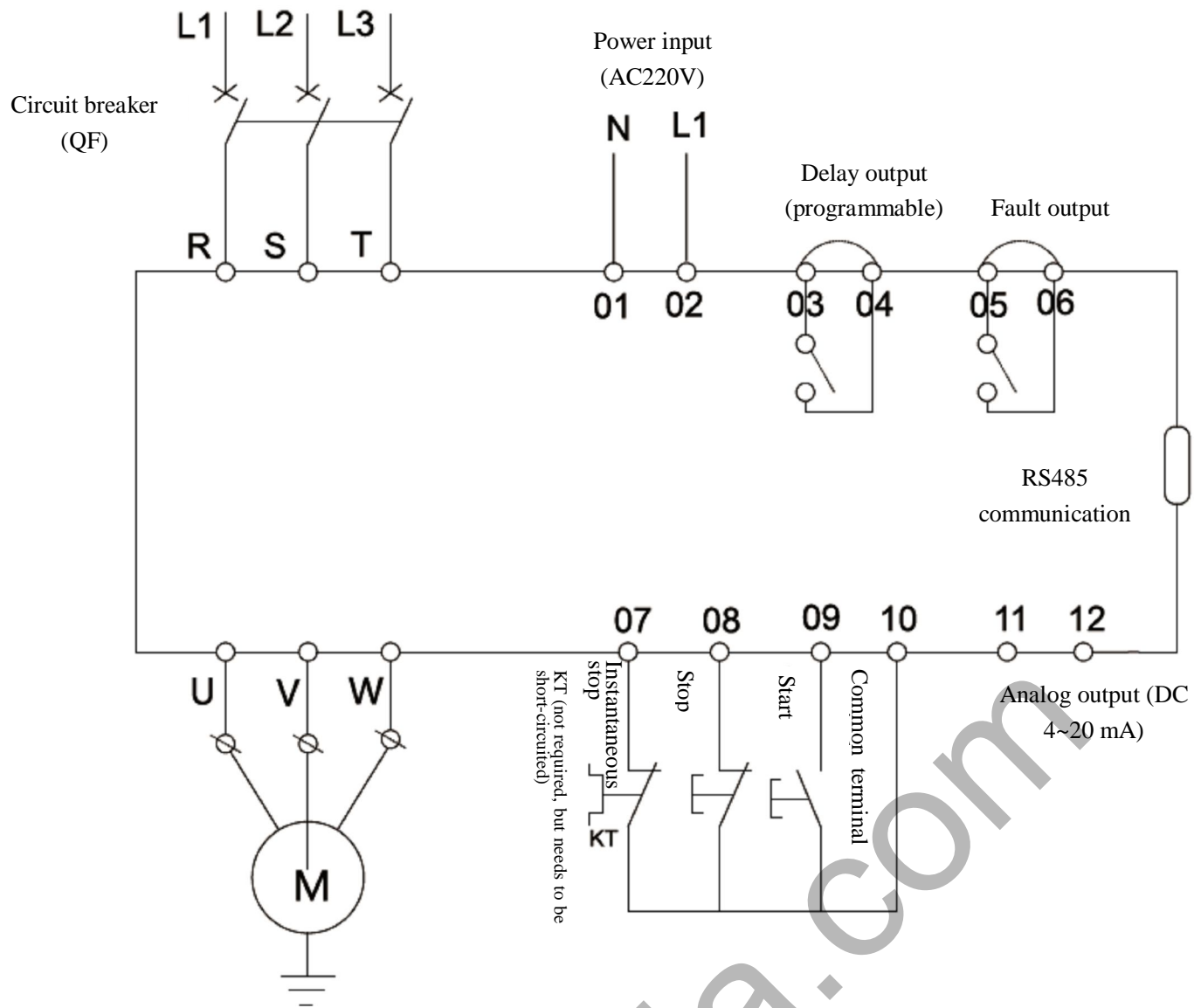

2-9 Terminal configuration diagrams

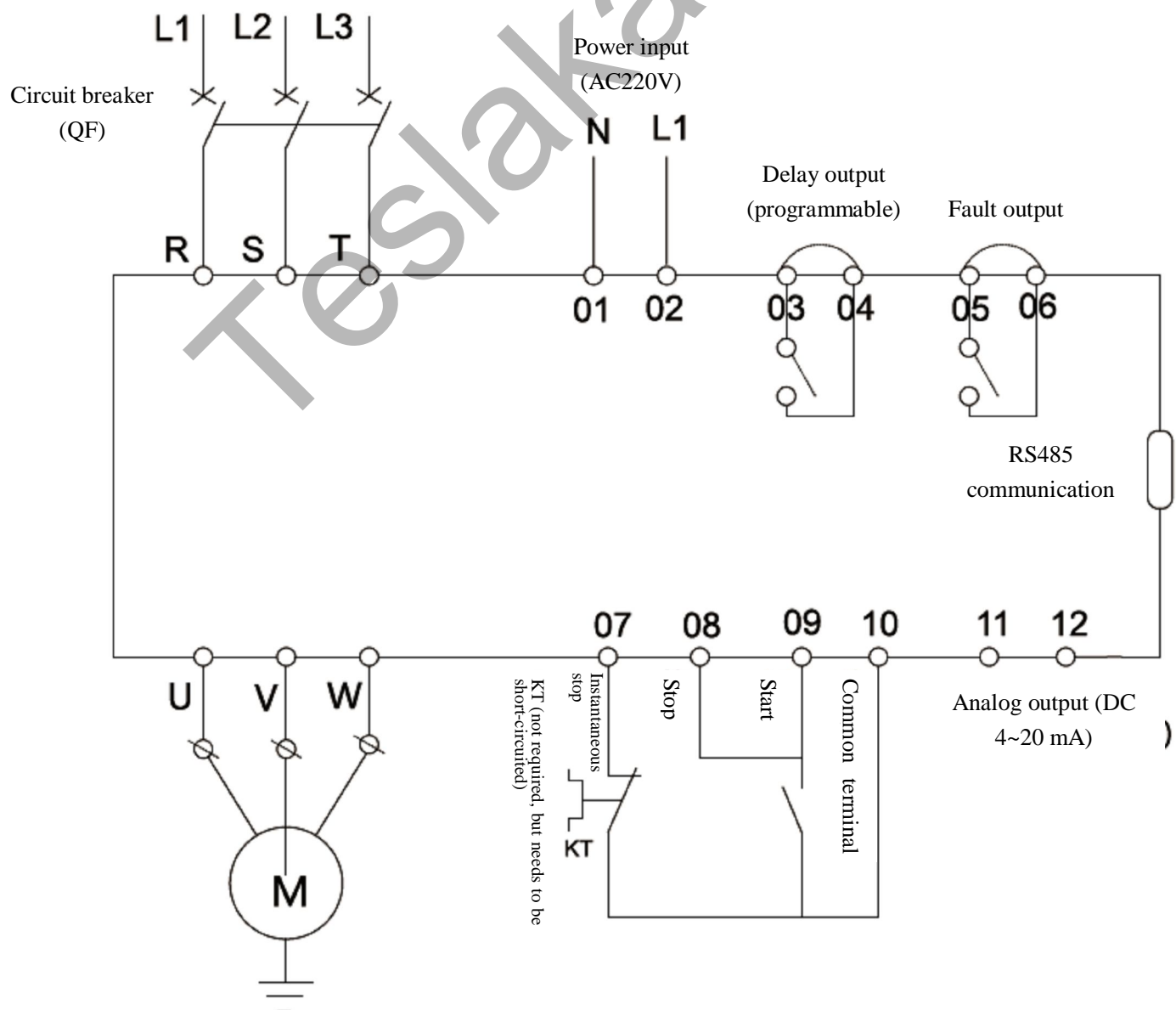

### 3. Running

#### 3-1 Inspection and preparation before running

The following should be inspected and prepared before starting running:

- (1) Check if the connections are correct or not, particularly, the output terminals should not be connected to the power, and confirm if the grounding terminal is well grounded or not.
- (2) Confirm there's no short circuit or short circuit to earth between the terminals or the exposed live parts.
- (3) Upon the power is connected, the keyboard panel shall display (Shanghai SANYU) or [ready] status.

#### 3-2 Running method

Select appropriate operation method as required, the soft starter is set to be panel controlled when delivery

- Upon the power is connected, the keyboard panel shall display (Shanghai SANYU) or [ready] status, press the start button, the motor will be started.
- Input setting entry FP according to the rated current value on the name plate of the motor.
- Upon start, check if the rotation direction of the motor is correct or not, if no, press the stop button to stop the motor or cut off the power if necessary, then switch any two wires of the motor (U,V,W).
- If the motor fails to reach good start status, refer to the section of starting mode and application of the soft starter in page 12 to select proper settings.
- If the torque fails to reach good effect, change the starting voltage code F0(under voltage mode) or current limiting code F5 (under current mode) to increase the start torque of the motor.
- Once power of the soft starter is on, please do not open the cover, otherwise there maybe risks of electric shock.
- In the process of trial running after power on, if there's any abnormal phenomenon, such as abnormal sound, smoke or odor, please cut off the power immediately and find out the causes.
- Press the stop button or external control stop button to reset the fault status.

Note: when the ambient temperature is below  $-10^{\circ}\text{C}$ , please get the power on and start the soft starter after preheating for 30mins.

## 4. Keyboard Panel

### 4-1 External of the keyboard panel

The keyboard panel contains abundant operation functions, such as running and stop functional data confirmation and change of the keyboard panel and functions of various status confirmation.



Table 4-1-1 functions of the operational buttons

Button description	Major functions
RUN	Press this button to start the soft starter when [ready] status is displayed, meanwhile run status -0000 will be displayed.
STOP	1. When A000 (current value) is displayed in normal running, press this button to stop the motor, -000 will be displayed in soft stop. 2. The button has the function of resetting the fault status.
SET	When [ready] status is displayed, press this button to enter menu setting, press this button again when F0: 40 is displayed, the colon will be flashing, then the parameters can be modified through pressing the up or down button.
YES	1. Press this button to save the modified parameter, displaying of "good" with two sounds given out indicate that the data has been saved, then press this button again or the stop button to exit. 2. Press this button to display input power voltage, AC380V 3. Press yes to get the power on, the set parameters will reset to factory defaults'
AV	1. Enter the menu setting to modify parameters(this button will be used to modify the function code when the colon is not flashing and be used to modify the data code when the colon is flashing ) 2. During running, this button can be used for observing the display of the running A current, P power and H overloading heat balance.

The keyboard panel can be disassembled, (placed outside the cabinet for operation), the lead distance should be <3m.

## 5. Basic Functions

### 5-1 Code setting function

Parameter setting code are shown in the below table

Code setting description				
Code	Description	Setting range	Factory default	Remarks
F0	Starting voltage	30-80%	40%	Voltage ramp mode works; initial voltage of the current mode is 40%
F1	Soft start time	2-60s	16s	Current-limiting mode is invalid.
F2	Soft stop time	0-60s	0s	For the model with inbuilt bypass, the soft stop time must be set to 2s.
F3	Starting interval delay	0-999S	0s	Use the countdown method for delay, when it is set to 0, there will be no delay and the motor will start immediately
F4	Time delay Programming	0-999S	0s	Used in programmable relay output
F5	Starting limiting current	50-500%	330%	Current-limiting mode works, maximum current-limiting value of random ramp mode of voltage is 400%
F6	Maximum working current	50-200%	100%	Percentage of the rated current of the motor.
F7	Under-voltage protection	40-90%	70%	Protection will be provided when the value is below the set value
F8	Overvoltage protection	100-140%	120%	Protection will be provided when the value is over the set value
F9	Starting mode	0-5	1	0 current limiting 1 voltage, 2 kick current 3.kick+ voltage, 4 current ramp 5 double closed-loop
FA	Protection level	0-4	2	0 primary 1 light load 2. standard 3.heavy load 4. advanced
FB	Control mode	0-6	4	0 keyboard, 1 keyboard+ external control 2 external control, 3 external control+ communication 4. keyboard+ external control+ communication, 5 keyboard+ communication,6 communication
FC	Allowed parameter modify	0-2	1	Refer to notes P13: 6-2 for details
FD	Communication address	0-63	0	Used in multi-machine communication between several soft starters and the host computer
FE	Programming output	0-19	7	Run the output (03,04 terminal) setting of the relay
FF	Soft stop current-limiting	20-100%	80%	Refer to notes P12:12-6 for details
FP	Rated current of the motor		Rated value	Used to input the nominal rated value of the motor
FU	Bypass time delay	0~40S		
FL	Unbalance permit loss-phase permit	0~3		0 unbalance close+ loss-phase close 1 unbalance close+ loss-phase permit 2 unbalance permit+ loss-phase close; 3 unbalance permit+ loss-phase permit

Note: 1. Maximum operation current of setting entry F6 means the maximum current calculated based on the FP setting ,it allows the motor to run continuously, inverse time limit thermal protection will be provided when this value is being exceeded.  
 2. In the setting status, if no button operation is conducted within 2 min, the setting status will be automatically exited.  
 3. Parameters can be set in all states except for soft start and soft stop process.  
 4. Press YES to get the power on and start the motor will reset the parameters (other than FE) to factory defaults.  
 5. Setting entry FL is used in the situation where the soft starter is unable to operate normally due to external interference or damage of mutual inductors in the practical operation, rather than the real imbalance or phase loss.

## 6. Detailed Description of the Function Selection



### 6-1 Code FE used in program setting to run the output relay action time

- There're two working methods of programmable relay output function, namely, programmable time sequence output method and programmable status output method. When the setting entry FE is between 0~4 (10~14), the programmable output works in time sequence method to set the starting time.

As shown in the below table:

Value set by FE	0 (10)	1 (11)	2 (12)	3 (13)	4 (14)
Output time of programming	When starting command is given	At the beginning of starting	When the bypass is running	When stop command is given	When stop has been completed

- Under this operation method, there's a 999s timer which is set by setting entry F4. If the value of F4 is not 0, delay will be started according to the initial time set by this setting entry F4.
- Timing until the output status changed. Resetting time of this output will be based on the time set by F4, that is, when the delay is ended, keep the soft starter under the ready status for 1s.
- Control cycle of the programmable time sequence method is a starting process, if the motor is re-started, then the previous programming output process will be automatically suspended and re-started.
- When the setting entry FE is between 5~9(15~19), the programmable output terminal will output according to the set operation status.

As shown in the below table:

Value set by FE	5 (15)	6 (16)	7 (17)	8 (18)	9 (19)
Output time of programming	Fault output	Running status	Ready status	RUN status	Start status

- Programmable status output method is used to indicate the operating status of the soft starter, the factory default 7 of setting entry FE indicates the ready-for-operation status of the soft starter, the motor can be started under this status; the programmable output in fault status indicates the faults of the motor(Err05, Err06, Err07, Err08, Err012, Err15), it is different from the functions of the No.⑤, ⑥ fault output terminals; running status refers to the non-set up fault status which includes the three processes of starting, bypass and soft stop.
- When FE>9, resetting status of the programmable output (No.③ ④ external terminals) will be changed from the normally disconnected to connected, namely, inverted output. Using the programmable relay output functions flexibly will simplify the peripheral control logic circuit effectively.

### 6-2 Code FC's parameter modification permitting function

- Setting entry FC is the parameter modification permitting option, including three types:
- When the setting entry FC is 0, no parameter can be modified except for the setting entry FC.
- When the setting entry FC is 1, value of the setting entries F4, F6, FD, FE, FF, FU shall not be modified.
- When the setting entry FC is 2, value of all setting entries can be modified.

## 7. Operation Steps

### 7-1 Modification of the setting parameters

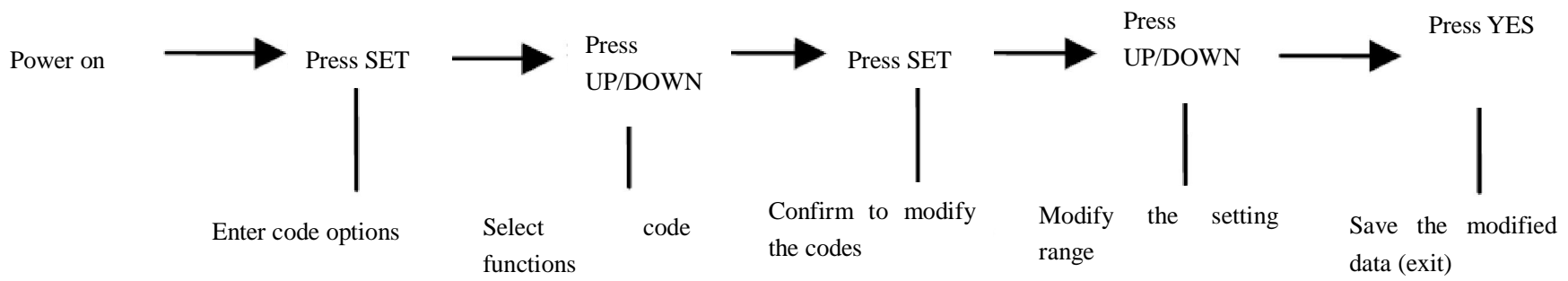

In case of modification, (take the operation control method as external terminal control, that is, the setting of code FB is 2 for example)

No.	Operation	Display	Remarks
1	Power on	SHSY [Ready] status	[Ready] status
2	Press SET	F0:40% initial voltage	Enter function code options status
3	Press UP	Fb: 40 control method: buttons are externally connected.	Enter code FE (control method) function options status.
4	Press SET	Fb:04 control method	Flashing colon indicates the setting range can be modified.
5	Press Down	Fb:02 control method: external control	Indicates external terminal control
6	Press YES	Good: data saved successfully	Modified data saved.(exit) [Ready] status, shanghai SANYU

When operating the keyboard, the internal buzzer of the soft starter will give sound for prompt.

## 8. Help Information

### 8-1 Help information and description

Display	Description
AC:XXXX	Four-digit voltmeter, used to test the voltage of the three phase AC power.
XXA-XXV	Indicate the specification of the soft starter
H1:Err0r00	Indicate that the latest fault information is zero
H2:Err0r00	Indicates no occurred fault information
H3:Err0r06	Indicates the occurred fault information Err0r06
...	...
H9:Err0r00	Indicates no fault information
Ver:4.2	Indicates the software version of the product is Ver4. 2
LXXXX	The total times of successful starting
T-run	Time used in last soft start(whether succeed or not)
Note: H1~H9 saves the recent 9 fault information in the recursive method	

- The help information can be assessed when the soft starter is not in the soft start/ soft stop status or the setting status; press Yes(button for confirmation), then press the up/down buttons to read the prompt messages.
- Press Yes or Stop to exit in the help status.

## 9. Protection Functions

### 9-1 Description of protection functions

SJR2 series soft starter possesses complete protection functions to protect the operation security of the soft starter and the motor. During operation, the protection level and protection parameters should be properly set based on different circumstances.

- Over-heating protection of the soft starter: the protection will start when the temperature rises to  $80^{\circ}\text{C} \pm 5^{\circ}\text{C}$ , and it will stop when the temperature falls to  $55^{\circ}\text{C}$ (lowest).
- Delayed time of input phase loss protection: <3s.
- Delayed time of output phase loss protection: <3s.
- Delayed time of input three-phase unbalance protection: <3s. Taking the deviation of current in each phase is over  $50\% \pm 10\%$  as the criteria, when the load current is less than 30% of the nominal rated value of the soft starter, it is confirmed that the deviation will increase.
- Protection time of over-current during starting: the protection time shall be continued to be longer than 5 times of the maximum operating current of code F5, see table P16:9-2-1.
- Protection time of overloading in running: inverse time limit thermal protection shall be provided based on the maximum operating current of code F6, see the tripping protection time curve (figure 9-3-1).
- Delayed time for power under-voltage protection: when the power voltage is under the extreme value 40%, the protection time < 0.5s, when the power voltage is below the set value, the protection time < 3s.
- Delayed time for power overvoltage protection: when the power voltage is over the extreme value 130%, the protection time < 0.5s, when the power voltage is over the set value, the protection time < 3s.
- Delayed time for load short circuit protection < 0.1s, if the current is more than 10 times of the nominal rated value of the soft starter, this protection shall not replace the fuse or short circuit protection device.

The above time parameters are the periods from the valid signal being detected to the tripping protection directive being given; these parameters are for information only. In the event that the protection functions of the soft starter fails to meet the requirements of customers, special protection devices should be installed to ensure the safety.

**9-2 Protection function setting**

In order to fit different application occasions, there're five protection levels with the SJR2 series soft starters, including 0: Primary, 1: Light load, 2: Standard, 3: Heavy load and, 4: Advanced, all of which are set by the code FA.

- The primary protection inhibits the function of the external instantaneous stop terminal while only retains the overheating, short circuit protection and input phase loss protection during starting, it applies to the occasions when unconditional emergency starting is required, such as fire pump and so on.
- The three protection levels of light load, standard and heavy load all possess complete protection functions with the difference lies in the over-loading thermal protection time curve of the motor. Please refer to table 9-2-1 and figure 9-3-1 for the thermal protection time parameters.
- As for the advanced protection, the protection standard is stricter, while all other protection function parameters are the same as those of the standard protection.

Set by code FA		0 (Primary)			1 Light load			2 Standard			3 Heavy load			4 Advanced			Remarks
Protection level of overloading in running		None			Level 2			Level 10			Level 20			Level 10			Based on IEC6 0947-4-2 standard
Protection level of over-current in running		None			3s			15s			30s			15s			Calculated as the starting current is more than 5 times of the value set by F6
Tripping time list of overloading in running	Times of the current	3	4	5	3	4	5	3	4	5	3	4	5	3	4	5	Value listed in the table are typical values
	Tripping time(s)	4.5	3	1.5	2.3	1.2	7.5	4.6	2.3	1.5	4.5	2.3	1.5	2.3	1.2	7.5	

- Code FP should be set according to the rated current value on the name plate of the motor; otherwise, relative great deviation will be caused between the starting current and the protection current.
- The motor current set by code FP should not be less than 20% of the nominal current of the soft starter, when the motor current set by code FP is relative low, the sensitivity tolerance of the protection tripping operation will be greater.

**9-3 Protection tripping voltage curve**

Motor thermal protection tripping time curve based on IEC60947-4-2 standard is shown as follows:

Figure 9-3-1

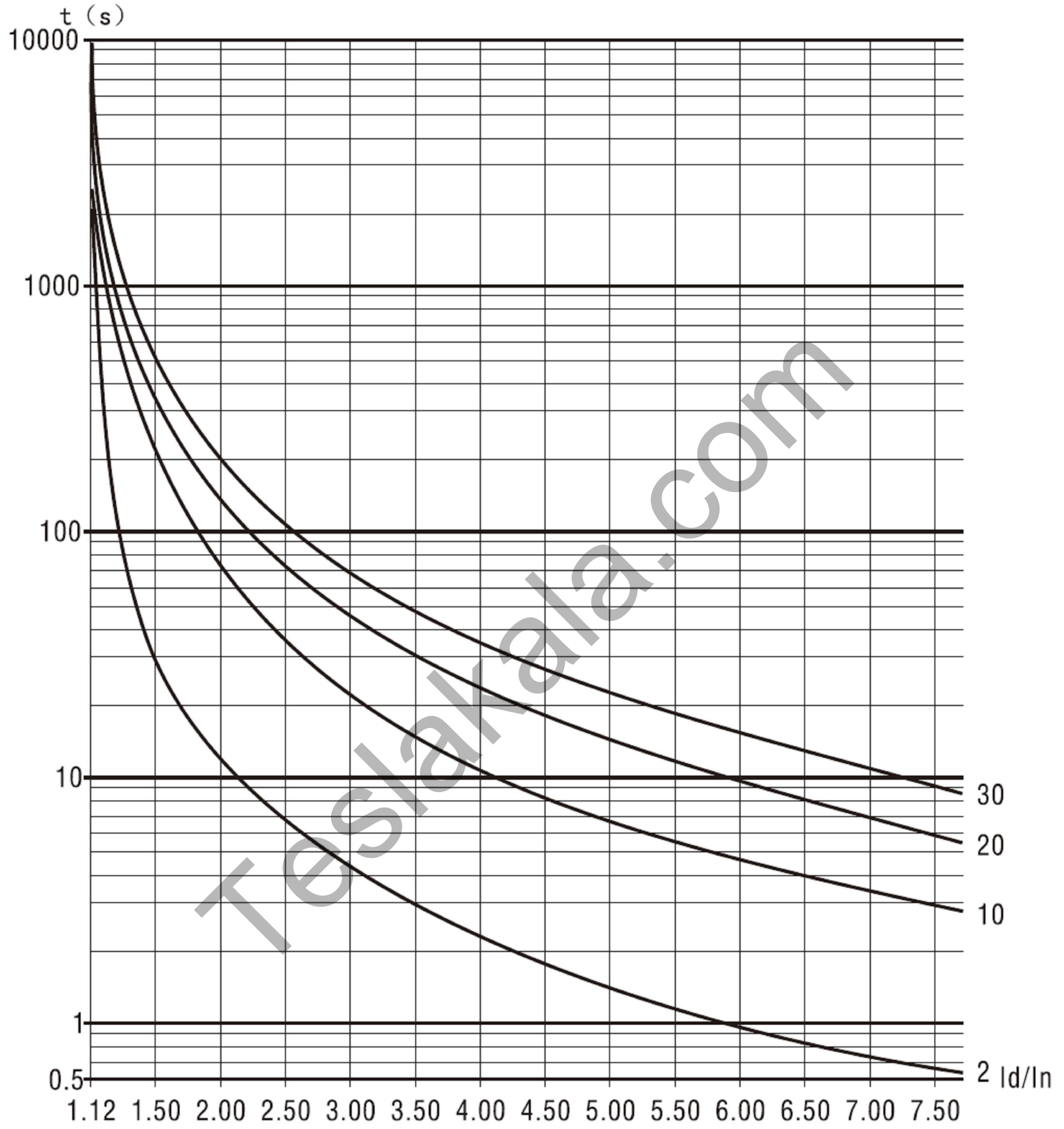

Motor thermal protection tripping time curve (thermal status)

## 10. Operated Protection

### 10-1 List of protective actions

In case of any exception with the soft starter, the protection function will act for tripping immediately. Please refer to remarks of table 10-1-1 for alarm description displayed in the LED and related contents.

Display	Description	Problems and Solution
Err00	Faults are removed.	There've just been under-voltage, overvoltage or overheating, instantaneous stop terminal disconnection and other faults which are removed now.
Err01	External instantaneous stop terminal opens circuit	Connect the external instantaneous terminal <sup>⑦</sup> to the common terminal <sup>⑩</sup> in short circuit, or connect such terminal to the normally closed contact point of other protection devices.
Err02	The soft starter is Overheating	starting too frequently or the power of the motor not matching the soft starter
Err03	Starting time is more than 60s.	Improperly set starting parameter or too heavy load or insufficient power supply capacity.
Err04	Input open-phase	Check if there's any fault with the input or the main circuit, or if the inbuilt bypass contactor is jammed in the close position or if the SCR is disconnected.
Err05	Output open-phase	Check if there's any fault with the input or the main circuit, or if the inbuilt bypass contactor is jammed in the close position or if the SCR is disconnected
Err06	Three-phase unbalance	Check for any exception with the input three-phase power supply or the load motor
Err07	Start over-current	Check if the load is too heavy or the power of the motor not matching the soft starter.
Err08	Overload protection during running	Check if the load is too heavy or if the parameters of setting entries F6, FP are improperly set.
Err09	Voltage of the power supply is too low	Check the input power supply voltage or if the parameter of setting entry F7 is improperly set.
Err10	Voltage of the power supply is too high	Check the input power supply voltage or if the parameter of setting entry F7 is improperly set.
Err11	Error with the parameter setting	Modify the setting or press Yes to get the power on and start the soft starter to reset the parameters to factory defaults.
Err12	Load short-circuit	Check if the load or SCR is short-circuited or if the load is too heavy.
Err13	Automatic restart, The connection is error	Check if the external control starting and stop end is connected to the two-wire mode or not.
Err14	The connection of external stopping terminal is error	When external control is permitted, the external control terminal is disconnected, so the motor can't get started.
Err15	Under loading of the motor	Check if any fault with the motor spindle or the load

Note: some faults are related to each other, e.g. Err02 overheating of the soft starter may be related to over-current during starting or load short-circuited. Therefore, it is necessary to consider comprehensively while finding out the fault to determine the fault point accurately,

Note: when the motor stops running again after successfully started by the soft starter, it indicates that such stop is caused by close failure of the bypass contactor, please check if there's any mistake or poor contact with the inbuilt bypass contactor or relevant connection.

## 11. Troubleshooting

### 11-1 Problems and solutions

Fault	Content	Solutions
The motor does not rotate.	If any abnormal power line is connected to the input terminals (R,S,T)	Please wire correctly and switch on ,then switch off and switch on again
	If the inbuilt bypass contactor runs normally	Check the connection of the inbuilt bypass contactor, check if it closes or not in the running status, check the coil connection of the inbuilt bypass contactor
	If any abnormal display in the keyboard	Please refer to the “List of Protective actions” in P18.
	If the motor is locked (if the load is too heavy)	Please unlock the motor(reduce the load)
Keyboard is failed to be started	If disconnection of terminal 07,10 are displayed on the keyboard or if the code FB is set correctly	No: if the power supply has phase loss, check the power input Yes: if 10 and 07,08 are disconnected, check the external connection of terminals Set code FB correctly
The external control cannot be started	If the code FB is set to external control	Check if terminals 10 and 07, 08 are disconnected, check the external connection, check if code FB is set to the external control or not, if no, set it correctly
The motor rotates but the speed stay the same	If the load is too heavy	Please reduce the load Increase the initial voltage or starting current
The starting time is too long	If the load is too heavy, if the code is set correctly or if the motor specification is normal	Please reduce the load Please set F0 (starting voltage), F5 (limiting current at start)
The starting time is too short	Time for starting with load is too short	The starting time is below the set value when the load is light, and it will be normal if it starts evenly, set code F1 starting time(invalid under current mode)
The motor comes to a sudden stop during running	Check the external input terminal	Check if the connection wires of terminals 07 and 10 become loose or not. If external protector is connected, please check if the normally closed point operates or if the connection wire of the external stop button become loose or not.

## 12. Starting Mode

### 12-1 Current limiting starting mode

- a) The soft starter will be under current starting mode when code F9 is set to 0 (current limiting). Figure 12-1 shows the current change wave of the motor under the current limiting mode.  $I_1$  is the set starting current limiting value, when the motor starts, the output voltage will increase rapidly until the current of the motor reaches the set current limiting value  $I_1$ , and the current of the motor will be kept under such value, then with the increasing of the output voltage, the motor will speed up gradually, and when the motor reaches the rated rotation speed, the bypass contact will close, the output current will drop rapidly to the rated current  $I_e$  of the motor or less, and the whole starting process completes.
- b) When the load of the motor is relatively light or the set current limiting value is relatively high, it will be normal that the maximum current may not reach the set current limiting value. Generally, current limiting starting mode applies to the occasions where there're strict limiting requirements on starting current.

Figure 12-1-1

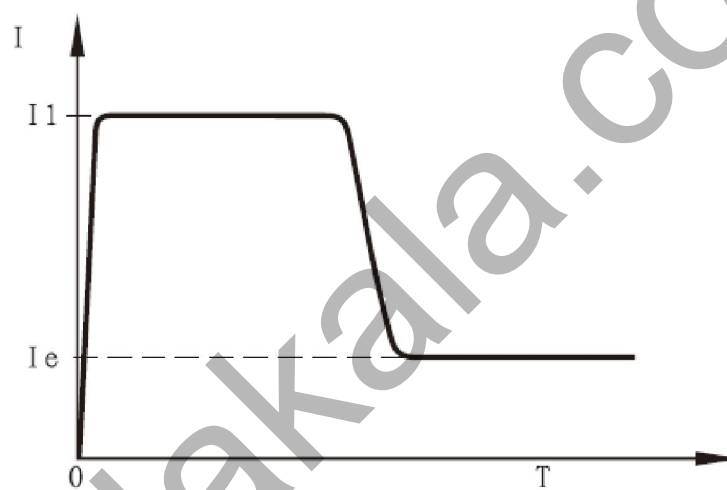

### 12-2 Voltage ramp starting

- a) The soft starter will be under voltage starting mode when code F9 is set to 1 (voltage). Figure 12-2-1 shows the output voltage wave of the output ramp starting.  $U_1$  is the starting voltage value at start, when the motor starts, if the current of the motor is within the range of the rated value 400%, the output voltage of the soft starter will increase to  $U_1$  rapidly, then the starting parameter set according to the output voltage will rise gradually, and the motor will accelerate smoothly with the rising of the voltage and reach the rated rotation speed when the voltage reaches the rated voltage  $U_e$ , then the inbuilt bypass contactor will close and the whole starting process completes.
- b) Starting time:  $t$  is the control parameter calculated from the standard testing condition based on standard load. Taking this parameter as the criteria, the SJR2 series soft starter enables the motor accelerates smoothly through controlling the output voltage to complete the starting process. This parameter is not the mechanical control time  $t$  which has nothing to do with if the motor accelerates smoothly or not. Given this, when the load is relatively light, the starting time will be less than the set starting time, and it will be normal as long as the starting process completes smoothly. Generally, the voltage ramp starting mode applies to the occasions where high requirements are not placed in the starting current but in the starting smoothness.

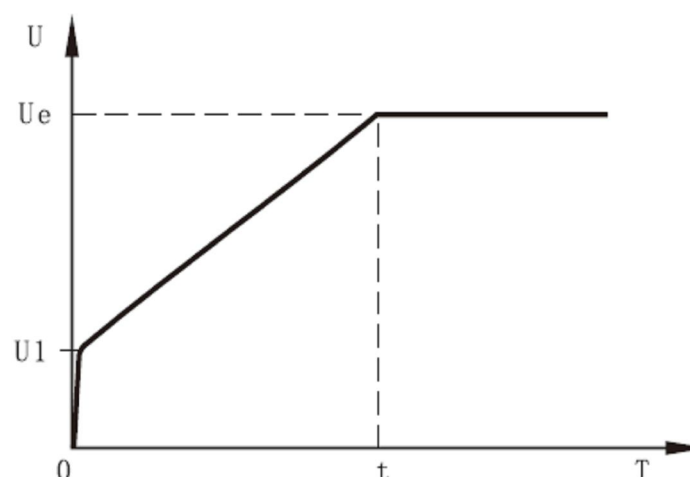

Figure 12-2-1



**12-3 Kick mode**

- a) The soft starter will be under kick starting mode when code F9 is set to 2(kick+ current limiting) or 3(kick + voltage). Figure 12-3-1 and 12-3-2 show the output change wave of the kick starting mode. In some occasions with heavy load, this starting mode can be used when the motor fails to be started due to effect of the mechanical static friction force. During start, apply a relatively high fixed voltage to the motor for a limited period to overcome the static friction force of the motor load to rotate the motor, then the motor will be started in the current limiting or fixed voltage ramp method.
- b) Before using this mode, the motor shall be started through the non-kick mode, and this mode shall be only used when the motor fails to rotate due to high friction, otherwise, starting with this mode shall not be used to reduce the unnecessary shock caused by large current.

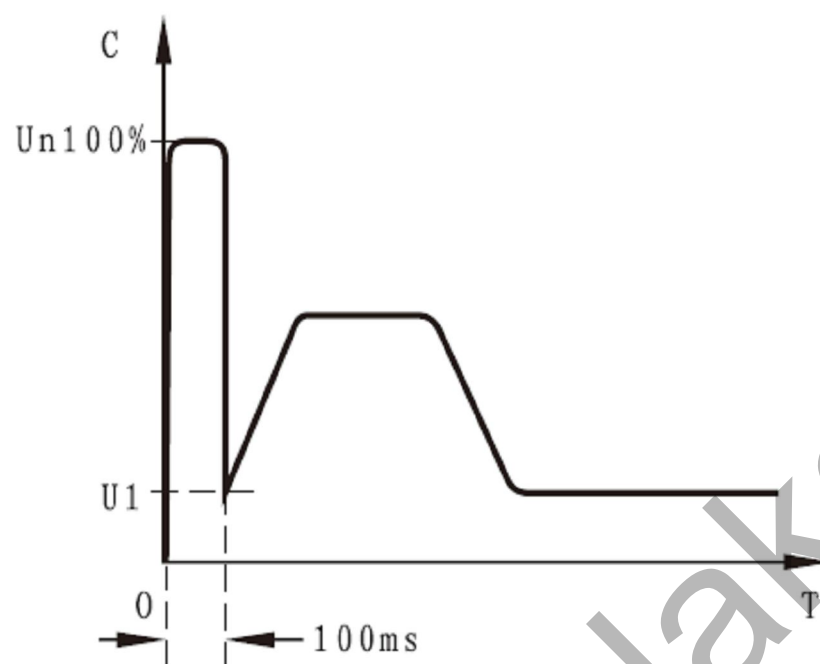

Figure 12-3-1

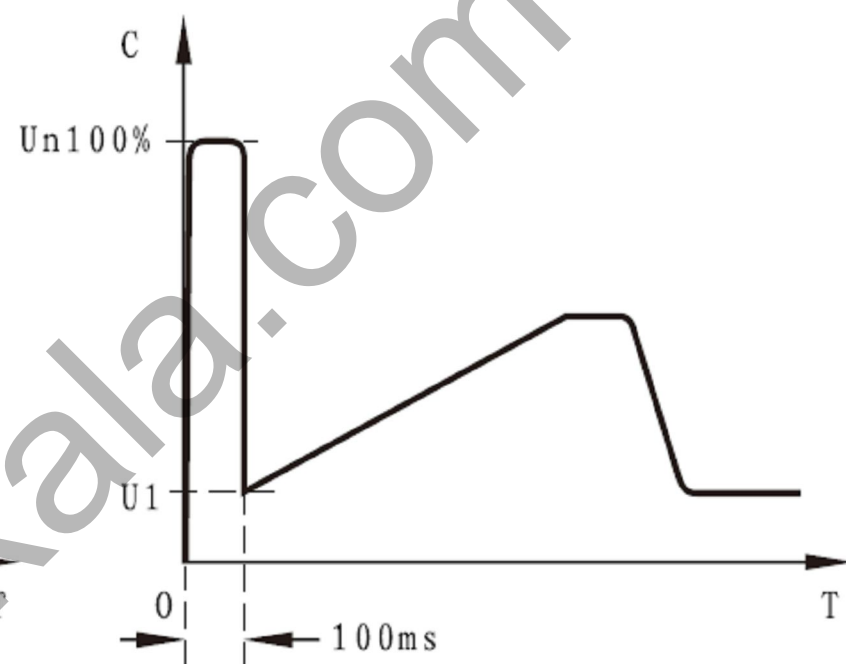

Figure 12-3-2

**12-4 Current ramp starting mode**

- a) The motor will be under current starting mode when code F9 is set to 4(current ramp). Figure 12-4-1 shows the output current wave of the current ramp starting mode, I1 is the time value set by code F1.
- b) The current ramp starting mode possesses strong accelerating capacity, when used in bipolar motor, it can shorten the starting time to a certain extent.

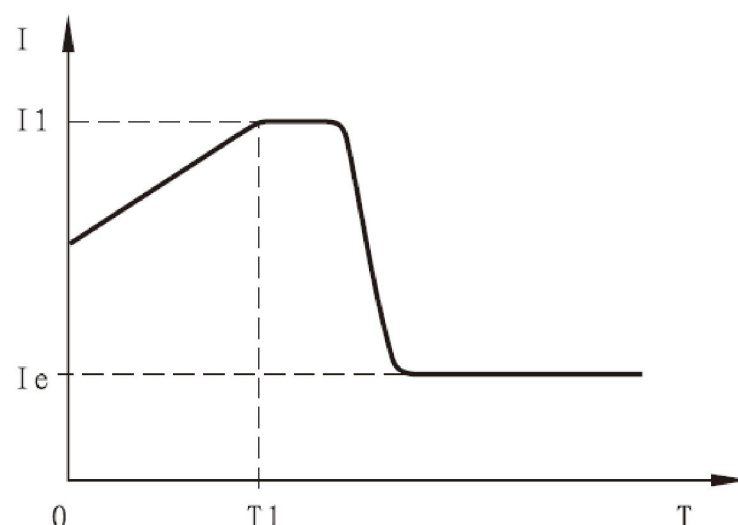

Figure 12-4-1

### 12-5 Voltage and current limiting double closed-loop starting

- a) The motor will be under double closed-loop starting mode when code F9 is set to 5(double closed loop). The voltage and current limiting closed-loop starting mode which adopts the double closed-loop control of voltage ramp and current limiting is a comprehensive starting mode requires both smooth starting and strict current limiting. It employs the prediction algorithm which estimates the operation status of the motor
- b) Output voltage wave of this starting mode varies with the motors and loadings.

### 12-6 Soft stop

There're two types of stop mode for SJR2 series soft starter, namely, soft stop mode and free stop mode.

- a) The soft starter will be under soft stop mode when code F2 is not set to 0. Figure 12-6-1 shows the output current wave of the soft stop mode. T is the soft stop time set by the code F2. Under this stop mode, power supply of the motor will be switched to thyristor output of the soft starter through the inbuilt bypass contactor, and the output voltage of the soft starter will gradually drop from the full voltage to enable the rotation speed of the motor reduce smoothly to avoid mechanical shock until the motor stops running. The output cut-off voltage during soft start shall be equal to the starting voltage during start.
- b) The soft stop mode can reduce and even eliminate surge of load of pumps and reduce the large current shock during soft stop. The soft stop current limiting value is the percentage calculated from the starting current limiting.

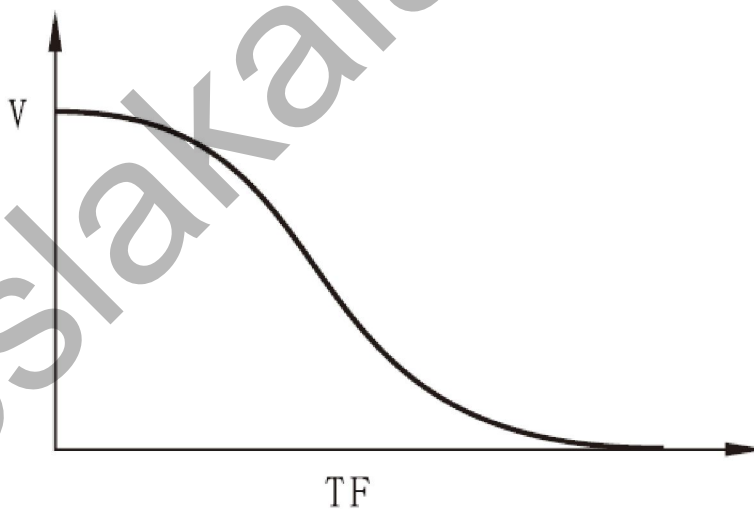

Figure 12-6-1

### 12-7 Free stop

- a) The soft starter will be under free stop mode when code F2 is set to 0(free stop). Under this type of stop mode, upon receiving the command, the soft starter will disconnect the inbuilt bypass contactor immediately and prohibit the voltage output of the thyristor of the soft starter, and then the motor will gradually stop due to load inertia. The code can be set to this mode when the soft starter is under the one-to-N connection method to avoid the phase loss fault alarm during output switching.
- b) Generally, in order to prolong the service life of the soft starter, free stop mode should be selected if there' s no necessary for soft stop. The free stop mode fully inhibits instantaneous output and thus it can prevent the instantaneous large current shock in the special application occasions.

There are six different starting modes with the SJR2-3000 series soft starters which apply to various complicated motors and loading situations, among which users can select according to different application ranges.

### 13. External Dimensions

#### 13-1 External dimensions of 5.5kw-75kw

Please see the below table for the external and installation dimensions of SJR2-3000 series 5.5kw-75kw soft starter.

Table13-1-1

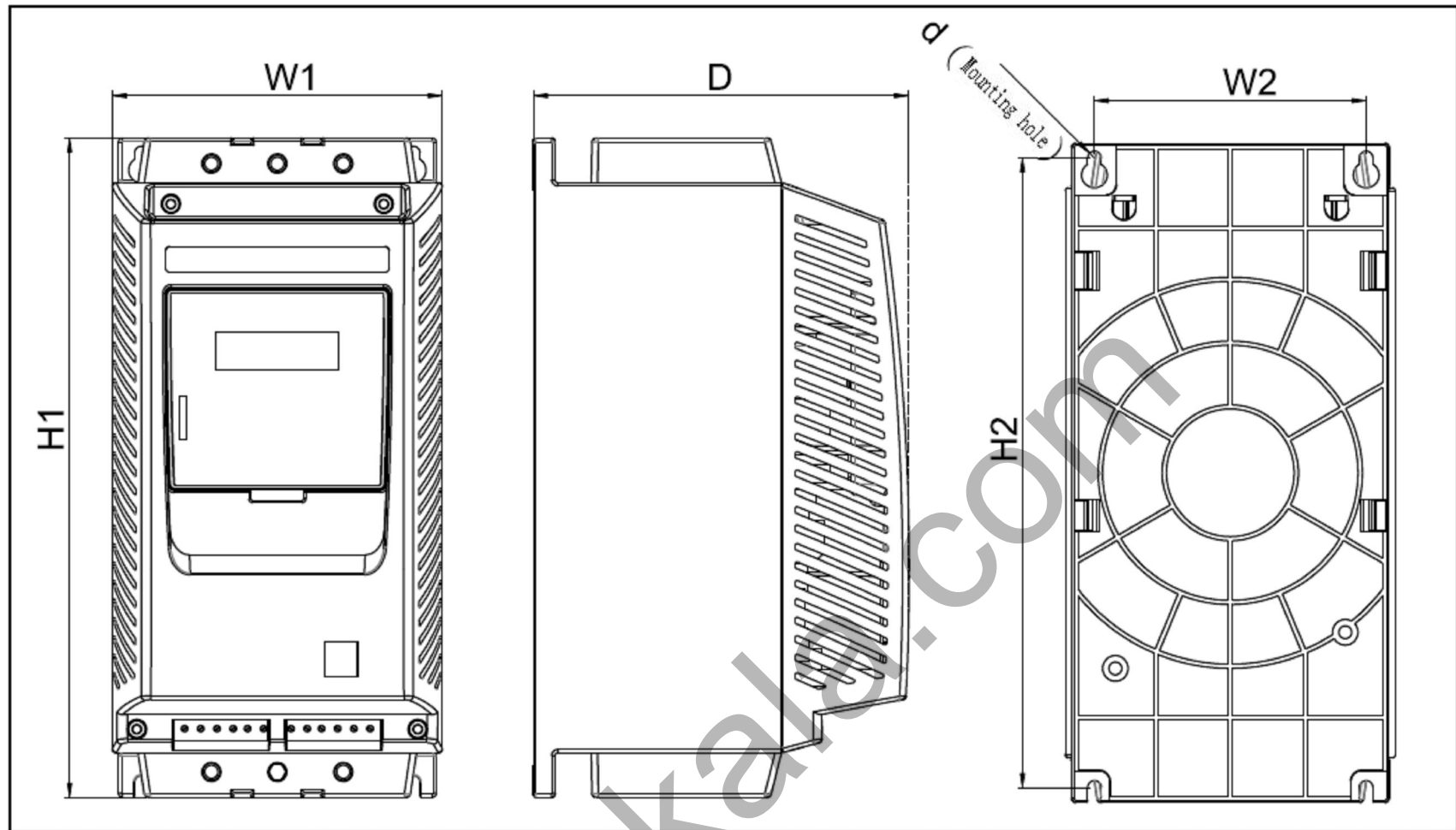

Model	Rated power (KW)	Rated current (A)	External dimensions			Installation dimensions			Net weight (kg)
			H1	W1	D	H2	W2	d	
SJR2-3005.5	5.5	11	310	155	175	296	128	M6	<5
SJR2-3007.5	7.5	15	370	155	176	296	128	M6	<5
SJR2-3011	11	22	370	155	176	296	128	M6	<5
SJR2-3013	15	30	370	155	176	296	128	M6	<5
SJR2-3018.5	18.5	37	370	155	176	296	128	M6	<5
SJR2-3022	22	43	370	155	176	296	128	M6	<5
SJR2-3030	30	60	370	155	176	296	128	M6	<5
SJR2-3037	37	75	370	155	176	296	128	M6	<5
SJR2-3045	45	90	370	155	176	296	128	M6	<5
SJR2-3055	55	110	370	155	176	296	128	M6	<5
SJR2-3075	75	150	370	155	176	296	128	M6	<5

- Rated power and rated current refer to the maximum rated values of the soft starter. Generally, corresponding parameters of the adaption motor shall not be greater than these values.
- Considering economic and applicable using, we made the 75kw types into large and small ones, under heavy load, the large one should be selected as table (13-2-1), and heavy load should be marked.

**13-2 External dimensions of 75kw-600kw**

Please see the below table for the external and installation dimensions of SJR2-3000 series 75kw-600kw soft starter.

Table 13-2-1

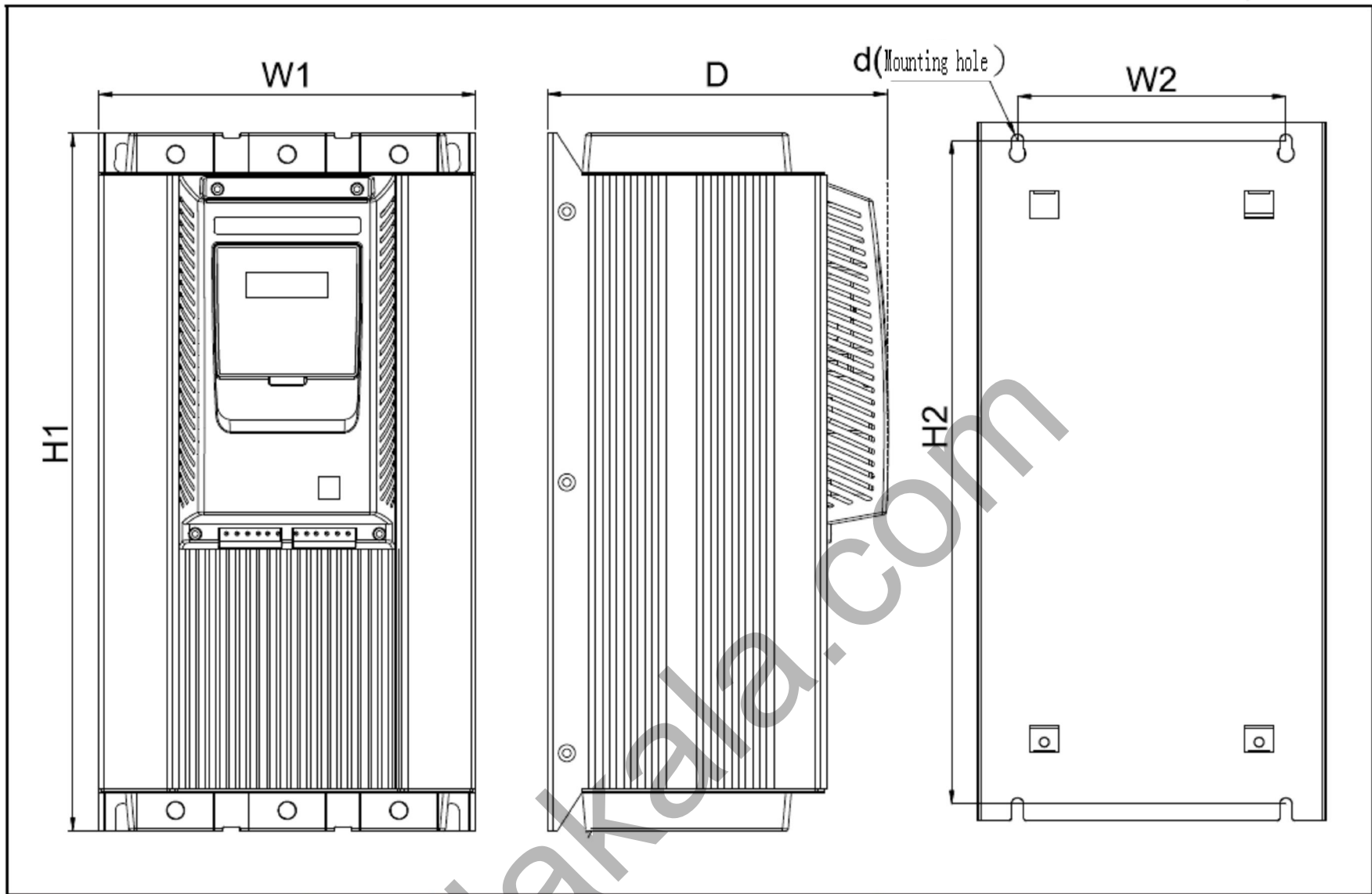

Model	Rated power (KW)	Rated current (A)	External dimensions			Installation dimensions			Net weight (kg)
			H1	W1	D	H2	W2	d	
SJR2-3005.5	5.5	150	525	265	240	490	235	M8	<20
SJR2-3007.5	75	180	525	265	240	490	235	M8	<20
SJR2-3011	90	230	525	265	240	490	235	M8	<20
SJR2-3013	115	264	525	265	240	490	235	M8	<20
SJR2-3018.5	132	320	525	265	240	490	235	M8	<20
SJR2-3022	160	400	525	265	240	490	235	M8	<20
SJR2-3030	200	500	525	265	240	490	235	M8	<20
SJR2-3037	250	560	550	300	265	515	260	M8	<20
SJR2-3045	280	640	550	300	265	515	260	M8	<23
SJR2-3055	320	800	550	300	265	515	260	M8	<23
SJR2-3075	75	150	550	300	265	515	260	M8	<23

■ Rated power and rated current refer to the maximum rated values of the soft starter. Generally, corresponding parameters of the adaption motor shall not be greater than these values.

## 14. Application Range

### 14-1 types of application load

SJR2-3000 soft starter can meet the requirements of most driving heavy load; the table below is for reference only.

Types of application load	Ramp time for starting(s)	Ramp time for stop (s)	Initial voltage (%)	Voltage starting (maximum current limiting value)	Current limiting starting
Centrifugal pump	16	20	40	4	2.5
Ball grinder	20	6	60	4	3.5
Fan	26	4	30	4	3.5
Light-load motor	16	2	30	4	3
Piston compressor	16	4	40	4	3
Lifting machine	6	10	60	4	3.5
Blender	16	2	50	4	3
Crusher	16	10	50	4	3.5
Screw compressor	16	2	40	4	3
Spiral conveyor belt	20	10	40	4	2
Screw conveyor	20	10	40	4	2.5
Heat pump	16	20	40	4	3

## 15. RS485 Communication

Through the inbuilt RS485 standard interface, the SJR2-3000 series soft starter can connect with PC and PLC and other hosts to conduct serial communication. The command of the host can control running or stop of the soft starter, monitor the running status of the soft starter and modify its functional data. Please refer to RS485 operation instructions for the detailed information of the communication. Remote operation, running command input, running status management, write-once of functional data of several soft starters can be conducted by means of the RS485 communication through computers to implement simplified operation during function codes input.

Major functions

1. Input of stop running command.
2. Monitoring of the running status
3. Real-time tracking (tabular display of the running information)
4. Read-once, write-once and saving to files of function codes. Please consult our company separately for the communication software.

### 15-1 MODBUS communication protocol

#### 15.1 Overview about Modbus RTU communication protocol

Modbus is a kind of serial asynchronous communication protocol with RS485 as the physical interface. Being designed for Modicon PLC, it has the structural features of PLC. In network control, it can read and write the SJR2-3000 as if it were a PLC. It can project the start and stop control, status information (current, fault etc.) and function parameters to the holding register (4XXX). Its read and write control shall be conducted through the PL master station.

15.1.1 Electrical interface

RS485 half duplex

Communication parameters: baud rate: 9600; 8 data bits; no check digit; 1 stop bit.

15.1.2 Format of the communication data:

Data format:

ID bit	Function code	Data zone	QRC verification
1 byte	1 byte	N bytes	2 bytes

15-2 related settings of the soft starter

15.2.1 Address of the register

Address of the register	Operation code	Function specification of the register
40001	06	Control word
40002	03	Status word
40003	03	Mean value of current*10
40004	03	Fault code
40256-40274	03&06	Function code of the soft starter

(1) Registers not listed above shall be illegal and shall not be written or read; otherwise the slave station will report an exception code to the controller.

(2) All data addresses are based on 40000, that is, the address of the coil relay is 0001 and address of 402567is 0100(hexadecimal)

15.2.2 Supported codes

The soft starter supports the following codes only, and exception code 01 will be reported if other codes are used.

Code	03	06
Function description	Read the register	Write the single register

Code 03 shall be read through WORD only

15.2.3 Description of the register

40001 command register

Bit	Value	Description
0	1	Soft starter starts
	0	Keep the status
1	1	The soft starter stops
	0	Keep the status
2	0-1	Reset the soft starter
3-15	0	Not used

For example, to start the soft starter form the slave station address 02, the controller will send 02 06 00 01 00 01, if the command is executed normally, code 02 06 00 01 00 01 will be returned. Whether the soft starter can start normally or not shall further be based on the status register. If there's any fault, send 02 06 00 01 00 04 to reset it.

Status register of register address 40002

The status register reflects the status of the soft starter; it is represented by one word.

Bit	Value	Description
0	1	Starting status
	0	Stop status
1	1	Running status
	0	Stop status
2	1	Soft stop status
	0	Stop status
3	1	Fault status
	0	Normal status
4-15		Not used

E.g. Read the status register codes 02 03 00 02 00 01

If the starter is in the process of starting, codes 02 03 00 02 00 01 will be returned.

If any fault with the starter, codes 02 03 00 02 00 08 will be returned, and types of fault can be read according to 4.

4003 mean value of current (hexadecimal)

The value projects the three-phase actual mean value of current\*10(including a decimal number)

E.g. Read the current value

Send codes 02 03 00 02 00 01

If the current is 235 A, codes 02 03 02 09 2E will be returned (actual current value shall be the returned value/10)

4004 fault codes (hexadecimal)

When the third number in status register is 1, it represents that the soft starter is in fault status. The fault codes shall be the same as those in 6.1

E.g.: send codes 02 03 00 04 00 01

If 02 03 02 00 04 are returned, it indicates the current input phase loss (fault code 04)

Function parameters register 40XXX of the soft starter

40256-40274 are function registers, the corresponding address are 0X0100-0X0112, the high byte address is 01, the low byte address are 0X00-0X12, the corresponding function codes are F0-FL, consistent with the function code table 4.2. For example, address 0X109 is corresponding to function code F9 (starting mode). These codes can be written and read. The usages are illustrated respectively:

Example 1 Read the value of function code F5 (current limiting value)

Send codes 02 03 01 05 00 01

The returned read value of F5 function code 02 03 02 01 5 E indicates the current limiting value is 350%

Example 2 Read function code FA (protection level)

Send codes 02 03 01 0A 00 01

The returned read value of FA function code 02 03 02 00 03 indicates the protection level is 3.

Example 3 Change the function code 05(starting current) of the soft starter to 250%

The host sends the codes 02 06 01 05 00 FA, the soft starter returns the codes 02 06 01 05 00 FA.

If codes 02 86 03 are returned, it indicates that writing failure, maybe the starter is running.

15-3 Exception response

Code	Description	Remarks
01	Illegal function	The function code cannot be executed, as it is not supported by the soft starter.
02	Illegal data address	The data address received cannot be executed .as the address is out of range.
03	Illegal data value	The data received cannot be executed. as 1. The parameter is beyond the amplitude limiting 2. The parameter cannot be modified 3. The parameter cannot be modified as the soft starter is running.

15.3.1 Illegal function code 01

Format of the master station inquiry message:

Substation address	Function code	High byte of the initial address	Low byte of the initial address	Upper bit of the number of registers	Lower bit of the number of registers	CRC Verification
0x01	0x08	0x00	0x80	0x00	0x0D	

As 0 x 80 function code is not used in the protocol, so for the substation response:

Substation address	Function code	Exception code	CRC verification
0x01	0x88	0x01	

15.3.2 Illegal data address 02

Format of the master station inquiry message

Substation address	Function code	High byte of the initial address	Low byte of the initial address	Upper bit of the number of registers	Lower bit of the number of registers	CRC Verification
0x01	0x04	0x01	0x80	0x00	0x07	

As register address of the 04 function code is incorrect, so for the substation response:

Substation address	Function code	Exception code	CRC verification
0x01	0x84	0x02	

15.3.3 Illegal data value 03

Format of the master station inquiry message

Substation address	Function code	High byte of the initial address	Low byte of the initial address	Upper bit of the number of registers	Lower bit of the number of registers	CRC Verification
0x01	0x04	0x00	0x80	0x01	0x08	

Number of registers of function code 04 is incorrect, so for the substation response:

Substation address	Function code	Exception code	CRC verification
0x01	0x84	0x03	

15-4 Notes for use

- (1) The communication address, communication rate and verification mode must be the same as the communication settings of the controller.
- (2) If no response data is received, please check the above parameter settings; check if the connection to 485 terminals is correct and if the CRC verification is correct.
- (3) In the event of communication among several TGS5, 120 Ω resistances should be connected at both AB ends of the last TGS5.
- (4) When connected to other Modbus equipments, connection should be conducted as per the diagram below:



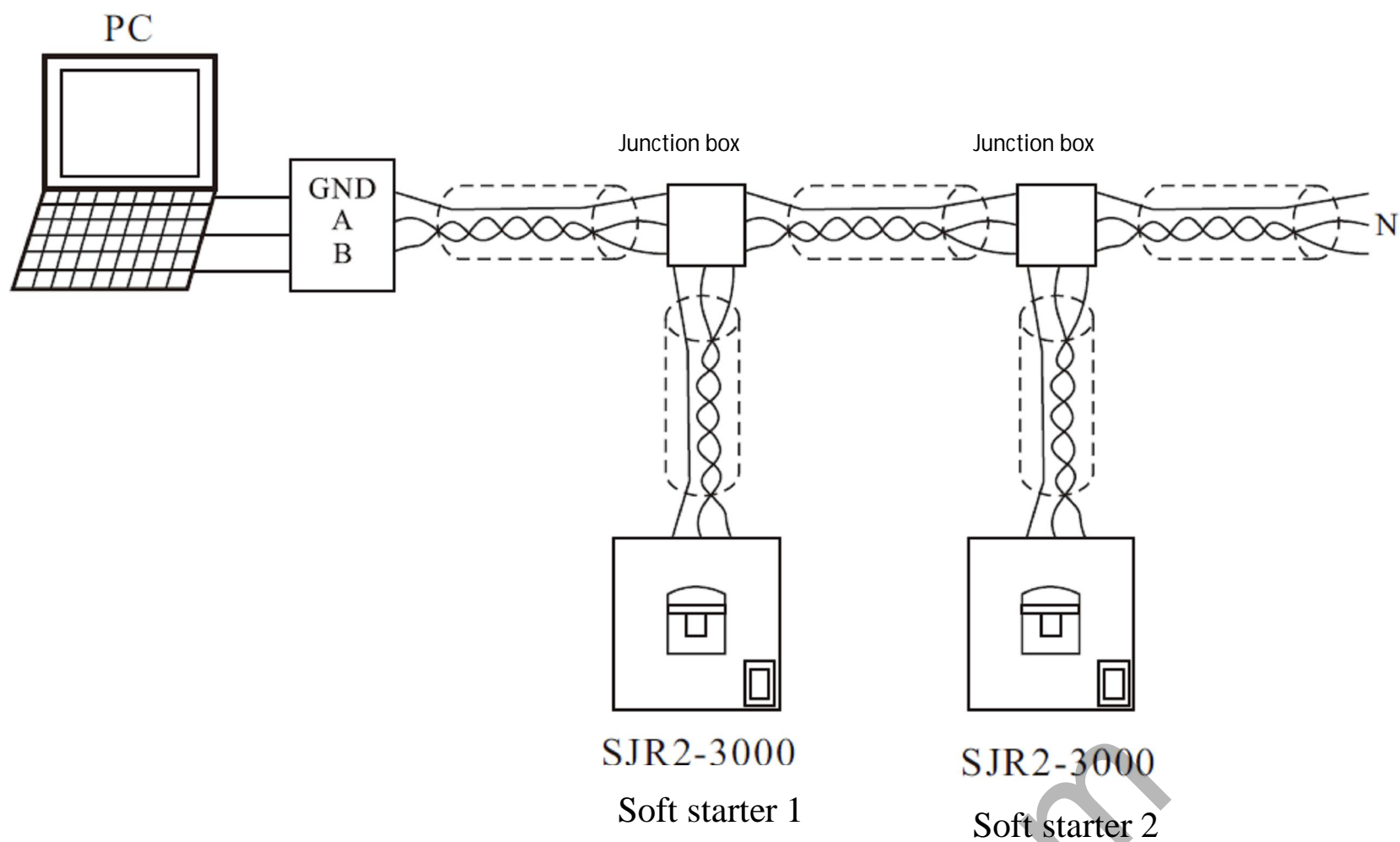

### Special Tips:

All soft starting products are of device types in case of delivery. In order to make it convenient for installation and debugging of the set manufactures, the output protection of the device-type soft starter has been set as “standard” when delivery. In installation and debugging, the set manufacturer can directly use a small motor or use three lamps to form a star to work as the load, then starting, stop, control and other operations can be conducted. However, in practical application, please be sure to change the output protection to “advanced”, and then the soft starter will possess the complete protection functions for phase loss, three-phase unbalance, over-current, overloading and so on. (Note: If the soft starter is reset to factory defaults, the output protection will be reset to “standard” again, so it will be necessary to set the protection level to “advanced” again). Please kindly note this.

**16. Annex**

**Warranty and After-sale Services**

Thanks for purchasing the soft starter manufactured by SANYU. The product is made under a perfect quality management system. For your convenience, we hereby give the following instructions with regard to the warranty and after-sale services:

1. Warranty

Warranty of the product shall be 12months from the purchasing date or 24 months from the manufacturing date recorded on the name plate, whichever is shorter. However, for any fault caused by the following reasons, regardless it is within the warranty or not, the repair shall be charged.

- 1) Incorrect use, unauthorized modification or improper repair.
- 2) Using beyond the standard specification requirements;
- 3) Damage caused by falling or occurred during shipping;
- 4) Earthquake, fire, wind disaster, lightning stroke, abnormal voltage, other Acts of God and secondary disasters.

2. After-sale services

- 1) If the soft starter fails to run in good status, please check first, and then check again by re-reading and referencing this instruction manual.
- 2) For any fault, please contact with the reseller or the “after-sale services department, office of our company” recorded in the instruction manual..
- 3) Repair within the warranty: free repair will be provided for any fault caused by the problems of manufacturing. However, all items in the “SANYU Starter Warranty Certificate” should be filled correctly and detailedly, otherwise, the repair will be charged.
- 4) Warranty expired: under the circumstance that the functions can be maintained after repair, paid repair will be provided as required by customers.

3. Service commitments

- 1) With regard to SJR2 series soft starter under 75kw (included), for any damage caused by non-artificial reasons within one year after purchasing, replacement will be provided, in the case of those ones over 75kw, for any damage caused by non-artificial reasons within one year after purchasing, repair will be provided, and upon expiration of such one year, paid technical service will be provided.
- 2) For technical support on using and operation of the soft starter: at the initial stage of using, our company will arrange technical service personnel to conduct debugging and installation on the site of customers and provide related technicians to support customer training with no charge.
- 3) We will response to the technical service and maintenance service requirements of customers in telephone within 24 hours upon receiving such requirements.
- 4) Upon receiving the debugging request of customers, if through transportation is available, we will arrive at the site of customer within 48 hours; for the area with traffic inconvenience, we will arrive at the site within 72 hours.

**SANYU Soft Starters Warranty Certificate**

Customer		Person in charge		Tel	
Customer address				Fax	
Model	SJR2-3_____KW	Manufacturing No.			
Store name for purchasing			Purchasing date:		
Address of the store			Date of fault		

**Fault condition**

Usage			Motor	_____KW	___polar(s)	model_____
Occurrence time	During continuous running    in accelerating    in decelerating    during power input    other					
Display of occurrence time	Alarm display    Keyboard display or not    Output voltage (Yes    No)					
Running after resetting	Yes    No    method of resetting    keyboard panel terminal    power supply    other					
Control terminals used	01, 02    03,04    05,06    07    08    09    10    11,12    Other					
Operation time		Frequency for finding out such fault	/	Installation site		
Power cut	Yes    No	Any abnormality with the surrounding machines		Historical fault		Yes (___times) No