

## YASKAWA AC Drive Option Complementary Type PG Installation Manual

Type: PG-B3

To properly use the product, read this manual thoroughly and retain for easy reference, inspection, and maintenance. Ensure the end user receives this manual.

### 安川インバータ オプション コンプリメンタリタイプ PG 取扱説明書

形 式 PG-B3

製品を安全にお使いいただくために、この取扱説明書を必ずお読みください。  
また、本書をお手元に保管していただくとともに、最終的に本製品をご使用になるユーザー様のお手元に確実に届けられるよう、お取り計らい願います。

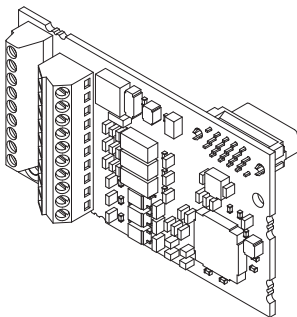

---

## **Copyright © 2016 YASKAWA ELECTRIC CORPORATION**

All rights reserved. No part of this publication may be reproduced, stored in a retrieval system, or transmitted, in any form or by any means, mechanical, electronic, photocopying, recording, or otherwise, without the prior written permission of Yaskawa. No patent liability is assumed with respect to the use of the information contained herein. Moreover, because Yaskawa is constantly striving to improve its high-quality products, the information contained in this manual is subject to change without notice. Every precaution has been taken in the preparation of this manual. Yaskawa assumes no responsibility for errors or omissions. Neither is any liability assumed for damages resulting from the use of the information contained in this publication.

# Table of Contents

---

<b>1</b>	<b>PREFACE AND SAFETY</b> .....	<b>4</b>
<b>2</b>	<b>OVERVIEW</b> .....	<b>9</b>
<b>3</b>	<b>RECEIVING</b> .....	<b>10</b>
<b>4</b>	<b>OPTION COMPONENTS</b> .....	<b>11</b>
<b>5</b>	<b>INSTALLATION PROCEDURE</b> .....	<b>12</b>
<b>6</b>	<b>RELATED PARAMETERS</b> .....	<b>36</b>
<b>7</b>	<b>TROUBLESHOOTING</b> .....	<b>39</b>
<b>8</b>	<b>EUROPEAN STANDARDS</b> .....	<b>43</b>
<b>9</b>	<b>SPECIFICATIONS</b> .....	<b>45</b>

## 1 Preface and Safety

YASKAWA Electric supplies component parts for use in a wide variety of industrial applications. The selection and application of YASKAWA products remain the responsibility of the equipment designer or end user.

YASKAWA accepts no responsibility for the way its products are incorporated into the final system design. Under no circumstances should any YASKAWA product be incorporated into any product or design as the exclusive or sole safety control. Without exception, all controls should be designed to detect faults dynamically and fail safely under all circumstances. All products designed to incorporate a component part manufactured by YASKAWA must be supplied to the end user with appropriate warnings and instructions as to the safe use and operation of that part. Any warnings provided by YASKAWA must be promptly provided to the end user. YASKAWA offers an express warranty only as to the quality of its products in conforming to standards and specifications published in the manual. **NO OTHER WARRANTY, EXPRESS OR IMPLIED, IS OFFERED.** YASKAWA assumes no liability for any personal injury, property damage, losses, or claims arising from misapplication of its products.

---

### ◆ Applicable Documentation

The following manuals are available for the option:

#### Option

<b>YASKAWA AC Drive Option PG-B3 Installation Manual Manual No: TOBP C730600 75C (This book)</b>	This guide is packaged together with the product and contains information necessary to install the option and set related drive parameters.
--	---

#### Yaskawa Drive

<b>YASKAWA AC Drive Manuals</b>	Drive manuals contain basic installation and wiring information in addition to detailed parameter setting, fault diagnostic, and maintenance information. The most recent versions of these manuals are available for download on our documentation websites: U.S.: <a href="http://www.yaskawa.com">http://www.yaskawa.com</a> Europe: <a href="http://www.yaskawa.eu.com">http://www.yaskawa.eu.com</a> Japan: <a href="http://www.e-mechatronics.com">http://www.e-mechatronics.com</a> Other areas: Check the back cover of these manuals. For questions, contact Yaskawa or a Yaskawa representative.
-------------------------------------	---

## ◆ Terms and Abbreviations

<b>Note:</b>	Indicates supplemental information that is not related to safety messages
<b>Option:</b>	YASKAWA AC Drive Option Motor PG Feedback Complementary: Type PG-B3
<b>Drive:</b>	<ul style="list-style-type: none"><li>• YASKAWA AC Drive 1000-Series (A1000, L1000A, U1000, U1000L)</li><li>• YASKAWA AC Drive GA700</li><li>• YASKAWA AC Drive GA800</li><li>• YASKAWA AC Drive CR700</li><li>• YASKAWA AC Drive CH700</li></ul>
<b>Keypad</b>	<ul style="list-style-type: none"><li>• LCD Operator for YASKAWA AC Drive 1000-Series</li><li>• LED Operator for YASKAWA AC Drive 1000-Series</li><li>• LCD Keypad for YASKAWA AC Drive GA700, GA800, CR700, and CH700</li><li>• LED Keypad for YASKAWA AC Drive GA700, GA800, CR700, and CH700</li></ul>
<b>PG:</b>	Pulse Generator or Encoder mounted on the motor
<b>V/f w/PG:</b>	V/f Control with PG
<b>CLV:</b>	Closed Loop Vector Control
<b>AOLV:</b>	Advanced Open Loop Vector Control

---

## ◆ Registered Trademarks

Trademarks are the property of their respective owners.

# 1 Preface and Safety

---

## ◆ Supplemental Safety Information

Read and understand this manual before installing, operating, or servicing this option. Install the option according to this manual and local codes.

The following conventions indicate safety messages in this manual. Failure to heed these messages could cause fatal injury or damage products and related equipment and systems.

### **DANGER**

**Indicates a hazardous situation, which, if not avoided, will cause death or serious injury.**

### **WARNING**

**Indicates a hazardous situation, which, if not avoided, could cause death or serious injury.**

### **CAUTION**

**Indicates a hazardous situation, which, if not avoided, could cause minor or moderate injury.**

### **NOTICE**

**Indicates an equipment damage message.**

## ■ General Safety

### General Precautions

- The diagrams in this book may include options and drives without covers or safety shields to illustrate details. Be sure to reinstall covers or shields before operating any devices. Use the option according to the instructions described in this manual.
- The diagrams in this manual are provided as examples only and may not pertain to all products covered by this manual.
- The products and specifications described in this manual or the content and presentation of the manual may be changed without notice to improve the product and/or the manual.
- Contact Yaskawa or a Yaskawa representative and provide the manual number shown on the front cover to order new copies of the manual.

### DANGER

#### **Heed the safety messages in this manual.**

Failure to comply will cause death or serious injury.

The operating company is responsible for any injuries or equipment damage resulting from failure to heed the warnings in this manual.

### WARNING

#### **Electrical Shock Hazard**

**Do not attempt to modify or alter the drive or drive circuitry in any way not explained in this manual.**

Failure to comply could cause death or serious injury and will void warranty. Yaskawa is not responsible for any modification of the product made by the user. Do not modify this product.

### NOTICE

**Do not modify the drive or option circuitry.**

Failure to comply could result in damage to the drive or option and will void warranty. Yaskawa is not responsible for any modification of the product made by the user.

**Do not expose the drive or the option to halogen group disinfectants. Do not pack the drive or the option in wooden materials that have been fumigated or sterilized. Do not sterilize the entire package after the product is packed.**

Failure to comply could damage the electrical components in the option.



## 2 Overview

The PG-B3 Option allows the user to connect an incremental encoder with complementary output (PG) for motor speed feedback to the drive to increase the control accuracy and performance in V/f w/PG, CLV, and AOLV control methods.

This PG encoder signal allows the drive to compensate for subtle variations in the load while providing the drive with the necessary data to control the output frequency and maintain an accurate constant speed.

The option reads a 50 kHz maximum input frequency from the PG encoder. Select a PG encoder with 50 kHz maximum output when operating at maximum speed.

### ◆ Compatible Products

The option can be used with the products in [Table 1](#).

**Table 1 Compatible Products**

Product Series	Model(s)
A1000	All models
L1000A	All models
U1000	All models
U1000L	All models
GA700	All models
GA800	All models
CR700	All models
CH700	All models

## 3 Receiving



After receiving the option package:

1. Make sure that the option is not damaged and no parts are missing. Contact your sales outlet if the option or other parts appear damaged.

**NOTICE:** Do not use damaged parts to connect the drive and the option. Failure to comply could damage the drive and option.

2. Confirm that the model number on the option nameplate and the model listed in the purchase order are the same. Refer to [Figure 1](#) on page 11 for details. Contact the distributor where the option was purchased or contact Yaskawa or a Yaskawa representative about any problems with the option.

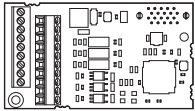
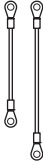
### ◆ Option Package Contents

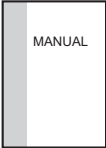
Description:	Option	Ground Wires <1>	Screws (M3)	Installation Manual
				
<b>Quantity:</b>	1	2	3 <2>	1

<1> GA700, GA800, CR700, and CH700 drives do not use the ground wire.

<2> GA700, GA800, CR700, and CH700 drives use two screws only.

### ◆ Installation Tools

- A Phillips screwdriver. Phillips screw sizes vary by drive capacity.
- A flat-blade screwdriver (blade depth: 0.4 mm (0.02 in), width: 2.5 mm (0.1 in)).
- A pair of diagonal cutting pliers.
- A small file or medium-grit sandpaper.

# 4 Option Components

## ◆ PG-B3 Option

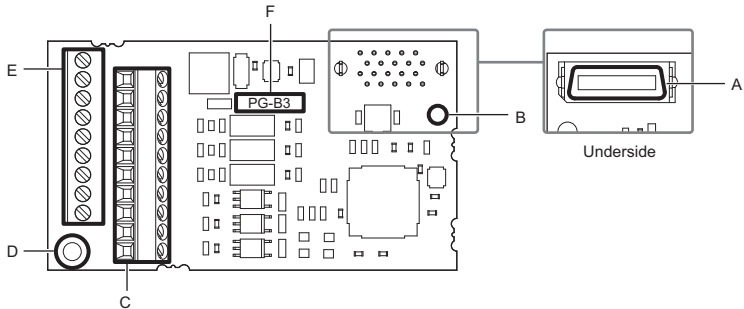

- A – Connector (CN5)
- B – Installation hole
- C – Terminal block TB2
- D – Ground terminal (FE) and installation hole <f>
- E – Terminal block TB1
- F – Option model number

<f> Connect the provided ground wires during installation. Installation to GA700, GA800, CR700, and CH700 drives does not require the ground wire.

Figure 1 PG-B3 Option Components

## ◆ Terminal Blocks TB1 and TB2

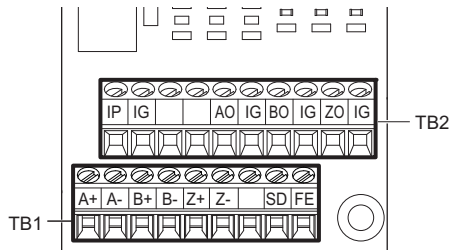

Refer to [Table 9](#) on page 35 for details on TB1 and TB2 terminal functions and signal levels.

# 5 Installation Procedure

### ◆ Section Safety

#### DANGER

##### **Electric Shock Hazard**

**Do not inspect, connect, or disconnect any wiring while the drive is energized.**

Failure to comply will cause death or serious injury.

Before servicing, disconnect all power to the equipment and wait for at least the time specified on the warning label. The internal capacitor remains charged even after the drive is de-energized. The charge indicator LED will extinguish when the DC bus voltage is below 50 Vdc. When all indicators are OFF, measure for unsafe voltages to confirm the drive is safe.

#### WARNING

##### **Electrical Shock Hazard**

**Do not operate equipment with covers removed.**

Failure to comply could cause death or serious injury.

The diagrams in this section may include options and drives without covers or safety shields to illustrate details. Reinstall covers and shields before operating the drive and run the drive according to the instructions described in this manual.

**Do not allow unqualified personnel to perform work on the drive or option.**

Failure to comply could cause death or serious injury.

Only authorized personnel familiar with installation, adjustment, and maintenance of AC drives and options may perform work.

**Do not remove covers or touch circuit boards while the drive is energized.**

Failure to comply could cause death or serious injury.

### **WARNING**

**Do not use damaged wires, stress the wiring, or damage the wire insulation.**

Failure to comply could cause death or serious injury.

#### **Fire Hazard**

**Tighten all terminal screws to the specified tightening torque.**

Loose or overtightened connections could cause erroneous operation and damage to the terminal block or start a fire and cause death or serious injury.

### **NOTICE**

#### **Damage to Equipment**

**Observe proper electrostatic discharge (ESD) procedures when handling the option, drive, and circuit boards.**

Failure to comply could cause ESD damage to circuitry.

**Never connect or disconnect the motor from the drive while the drive is outputting voltage.**

Improper equipment sequencing could damage the drive.

**Do not connect or operate any equipment with visible damage or missing parts.**

Failure to comply could further damage the equipment.

**Do not use unshielded wire for control wiring.**

Failure to comply may cause electrical interference resulting in poor system performance. Use shielded, twisted-pair wires and ground the shield to the ground terminal of the drive.

**Properly connect all pins and connectors on the option and drive.**

Failure to comply could prevent proper operation and damage equipment.

**Confirm that all connections are correct after installing the option and connecting peripheral devices.**

Failure to comply could damage the option.

## 5 Installation Procedure

---

### ◆ Procedures for Installing and Wiring Options on a Drive

Procedures for installing and wiring options differ depending on the drive model.

Refer to [Table 2](#) to check the procedures for installing and wiring options on a drive.

**Table 2 Procedures for Installing and Wiring Options on a Drive**

Product Series	Procedures for Installing and Wiring Options on a Drive	Page
A1000	Procedure A	<a href="#">15</a>
L1000A	Procedure A	<a href="#">15</a>
U1000	Procedure A	<a href="#">15</a>
U1000L	Procedure A	<a href="#">15</a>
GA700	Procedure B	<a href="#">24</a>
GA800	Procedure B	<a href="#">24</a>
CR700	Procedure B	<a href="#">24</a>
CH700	Procedure B	<a href="#">24</a>

### ■ Procedure A

This section shows the procedure to install and wire the option on a 1000-series drive.

#### Prepare the Drive for the Option

Before beginning the installation procedure:

1. Wire the drive and make the proper connections to drive terminals according to the manual packaged with the drive.
2. Verify that the drive functions normally.  
Refer to [Figure 2](#) for an exploded view of the drive with the option and related components for reference in the installation procedure.

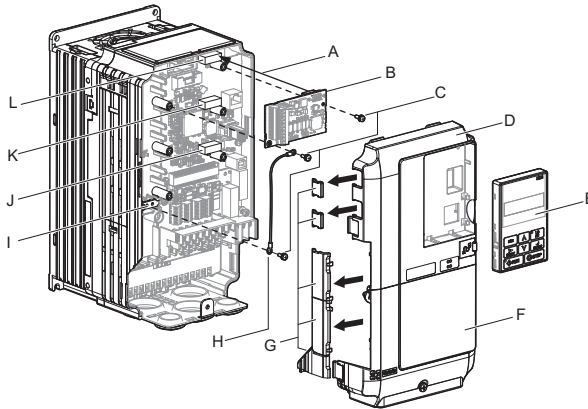

- |                                     |  |
|-------------------------------------|--|
| A – Insertion point for CN5         | H – Ground wire  |
| B – Option card                     | I – Drive grounding terminal (FE)                                  |
| C – Included screws                 | J – Connector CN5-A<br>(Not available for PG option installation.) |
| D – Front cover                     | K – Connector CN5-B  |
| E – Keypad                          | L – Connector CN5-C  |
| F – Terminal cover                  |  |
| G – Removable tabs for wire routing |  |

Figure 2 Drive Components with Option

## 5 Installation Procedure

---

### Install the Option

Refer to the instructions below to install the option.

**Note:** Refer to the instruction manual of a specific drive for information on removing and installing the keypads and the covers.

**DANGER!** *Electrical Shock Hazard. Do not inspect, connect, or disconnect any wiring while the drive is energized. Failure to comply will cause death or serious injury. Before servicing, disconnect all power to the equipment and wait for at least the time specified on the warning label. The internal capacitor remains charged even after the drive is de-energized. The charge indicator LED will extinguish when the DC bus voltage is below 50 Vdc. When all indicators are OFF, measure for unsafe voltages to confirm the drive is safe.*

1. Shut off power to the drive, wait the appropriate amount of time for voltage to dissipate, then remove the keypad (E), front cover (D), and terminal cover (F). Refer to the manual packaged with the drive for details on keypad and cover removal.

**NOTICE:** *Observe proper electrostatic discharge (ESD) procedures when handling the option, drive, and circuit boards. Failure to comply could cause ESD damage to circuitry.*

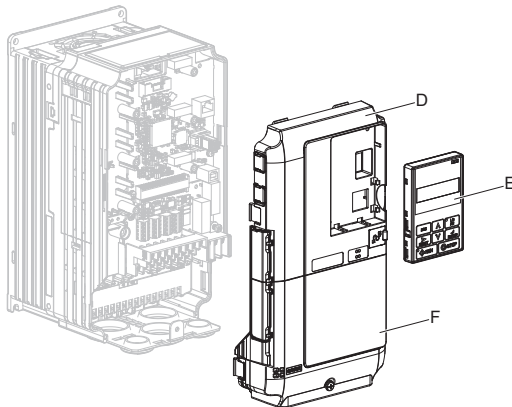

**Figure 3 Remove the Front Cover, Terminal Cover, and Keypad**



2. Insert the option card (B) into the CN5-B (K) or CN5-C (L) connector on the drive and fasten it into place using the included screws (C). Tighten both screws to 0.5 to 0.6 N·m (4.4 to 5.3 in·lb). Use the CN5-C connector (L) when connecting only one option to the drive; use both CN5-B (K) and CN5-C when connecting two options.

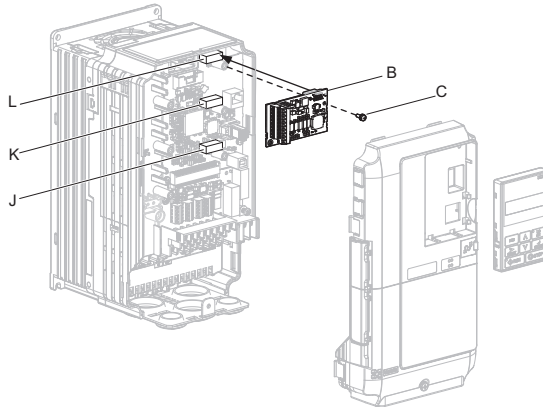

**Figure 4 Insert the Option Card**

## 5 Installation Procedure

3. Connect one end of the ground wire (H) to the ground terminal (I) using one of the remaining provided screws (C). Connect the other end of the ground wire (H) to the remaining ground terminal and installation hole on the option (B) using the last remaining provided screw (C).

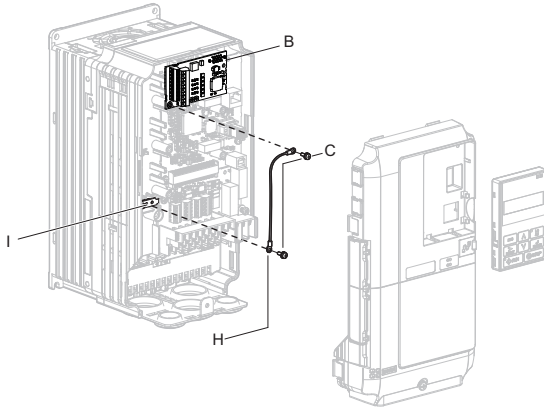

**Figure 5 Connect the Ground Wire**

- Note:**
1. The option package includes two ground wires. Use the longer wire to connect the option to CN5-C. Use the shorter wire to connect the option to CN5-B. *Refer to Option Package Contents on page 10* for more information.
  2. The drive has only two ground terminal screw holes (I). Two ground wires should share the same ground terminal when connecting three options.

- Prepare and connect the wire ends as shown in [Figure 6](#) and [Figure 7](#). Refer to [Wire Gauges and Tightening Torques on page 33](#) to confirm that the proper tightening torque is applied to each terminal. Take particular precaution to ensure that each wire is properly connected and wire insulation is not accidentally pinched into electrical terminals.

**WARNING! Fire Hazard.** Tighten all terminal screws according to the specified tightening torque. Loose electrical connections could result in death or serious injury by fire due to overheating electrical connections. Tightening screws beyond the specified tightening torque may result in erroneous operation, damage the terminal block, or cause a fire.

**NOTICE:** Heat shrink tubing or electrical tape may be required to ensure that cable shielding does not contact other wiring. Insufficient insulation may cause a short circuit and damage the option or drive.

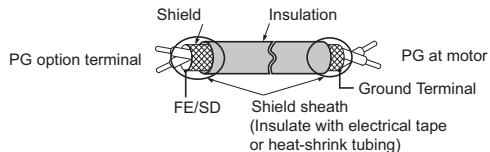

**Figure 6 Prepare Ends of Shielded Cable**

- Wire the motor PG encoder to the terminal block on the option according to [Figure 7](#). Refer to [Figure 21](#) for the PG-B3 Option and PG Encoder connection diagram. Refer to [Table 9](#) for a detailed description of the option terminal functions.

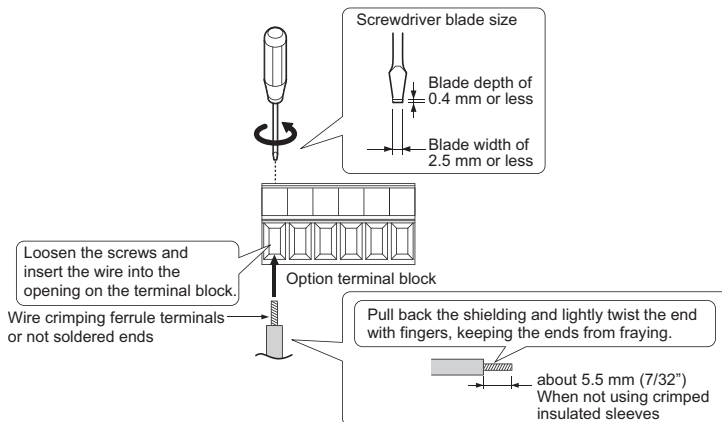

**Figure 7 Connect Cable Wiring**

## 5 Installation Procedure

**Table 3 Parameter Settings and Connections for Different Encoder Types**

PG Encoder type	Control Method	Number of PG Encoders	F1-21 Setting	F1-37 Setting
Single-Pulse (A)	V/f w/PG	1	0	N/A
		2	N/A	0
	CLV	1	N/A	N/A
		2	N/A	N/A
Two-Pulse (AB Quadrature)	V/f w/PG	1	1	N/A
		2	N/A	1
	CLV	1	None Required	None Required
		2	None Required	None Required
Two-Pulse with Z Marker	V/f w/PG	1	1	N/A
		2	N/A	1
	CLV	1	None Required	None Required
		2	None Required	None Required

6. Route the option wiring inside the enclosure as shown in **Figure 8-B**. Take proper precautions so that the front covers will easily fit back onto the drive. Users may also choose to route the option wiring through openings on the front cover of some models. Remove the perforated tabs on the left side of the front cover as shown in **Figure 8-A** to create the necessary openings on these models. Refer to the Peripheral Devices & Options section of the drive instruction manual for more information.

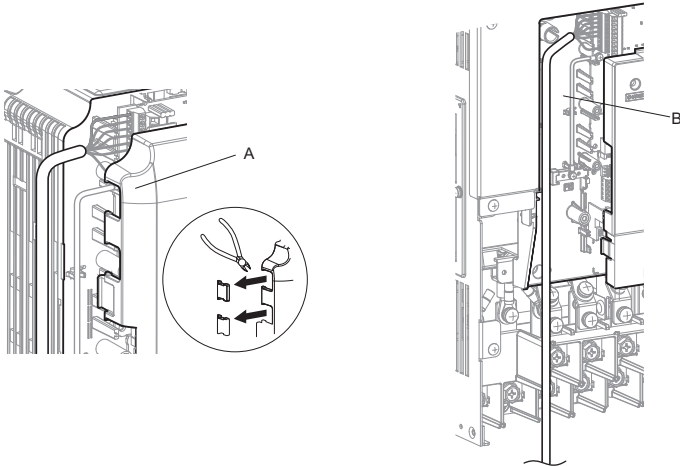

**A – Route wires through the openings provided on the left side of the front cover. <1>**

**B – Use the open space provided inside the drive to route option wiring.**

<1> The drive will not meet Enclosed wall-mounted type (IP20/UL Type 1) requirements if wiring is exposed outside the enclosure.

**Figure 8 Wire Routing Examples**

## 5 Installation Procedure

---

7. Reattach the front covers of the drive (D, F) and the keypad (E).

**NOTICE:** Do not pinch cables between the front covers and the drive. Failure to comply could cause erroneous operation.

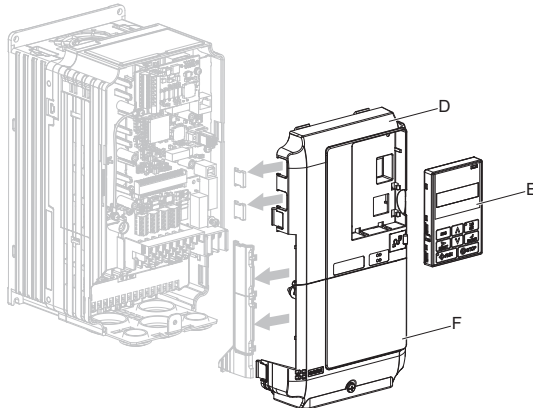

**Figure 9** Replace the Front Covers and Keypad

8. Connect the PG encoder outputs to the option.

9. Set drive parameters in [Table 10](#) for proper motor rotation.

The leading pulse determines the motor rotation direction with a two-pulse or three-pulse PG encoder.

PG encoder signals with leading pulse A are considered to be rotating forward (counter-clockwise when viewing rotation from motor load side).

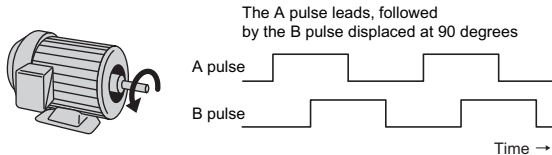

**Figure 10 Displacement of A and B Pulses**

10. Energize the drive and manually rotate the motor to check the rotation direction using monitor U1-05 on the keypad.

**WARNING!** *Sudden Movement Hazard. Lock out the Run circuit to prevent issuing a Run command prior to manually rotating the motor shaft with the drive energized. Failure to comply could cause death or serious injury.*

U1-05 Value	Motor Direction
Negative	Reverse
Positive	Forward

If necessary, either switch the two A channel wires with the two B channel wires on option terminal TB1 as shown in [Figure 11](#) or set F1-05/F1-32 to 1 to change the forward direction.

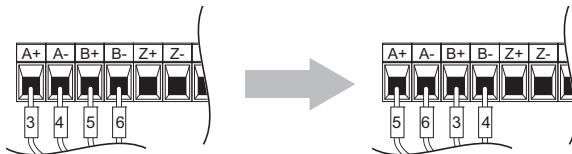

**Figure 11 Switch A Channel and B Channel Wires**

**Note:** Setting A1-03 = 1110, 2220, or 3330 will reset F1-05/F1-32 to factory default. Re-set the parameter to switch direction again.

## 5 Installation Procedure

### ■ Procedure B

This section shows the procedure to install and wire the option on a GA700, GA800, CR700, and CH700 drive.

#### Prepare the Drive for the Option

Before beginning the installation procedure:

1. Wire the drive and make the proper connections to drive terminals according to the manual packaged with the drive.
2. Verify that the drive functions normally.

Refer to [Figure 12](#) for an exploded view of the drive with the option and related components for reference in the installation procedure.

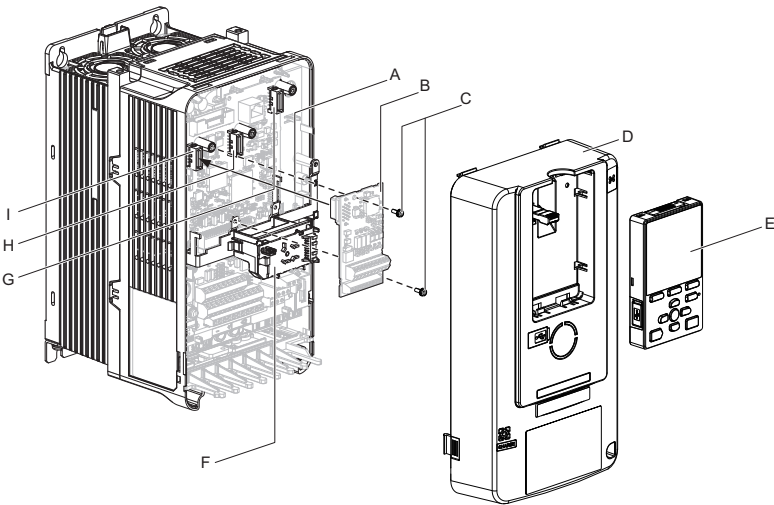

A – Insertion point for CN5 connector

B – PG-B3 option

C – Included screws

D – Drive front cover

E – Keypad

F – LED Status Ring board

G – Connector CN5-A  
(Not available for PG option installation.)

H – Connector CN5-B

I – Connector CN5-C

Figure 12 Drive Components with Option



### Install the Option

**DANGER! Electrical Shock Hazard.** Do not inspect, connect, or disconnect any wiring while the drive is energized. Failure to comply will cause death or serious injury. Before servicing, disconnect all power to the equipment and wait for at least the time specified on the warning label. The internal capacitor remains charged even after the drive is de-energized. The charge indicator LED will extinguish when the DC bus voltage is below 50 Vdc. When all indicators are OFF, measure for unsafe voltages to confirm the drive is safe.

1. Shut off power to the drive, wait the appropriate amount of time for voltage to dissipate, confirm all charge indicator LEDs extinguish, then remove the front cover (D) including the keypad (E). Refer to the manual packaged with the drive for details on cover removal.

**NOTICE:** Observe proper electrostatic discharge (ESD) procedures when handling the option, drive, and circuit boards. Failure to comply could cause ESD damage to circuitry.

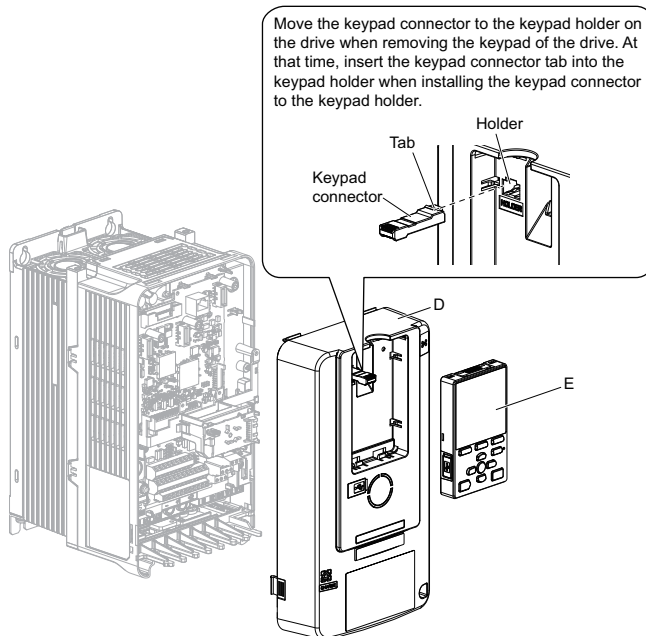

**Figure 13 Remove the Front Cover Including Keypad**

## 5 Installation Procedure

---

2. Carefully remove the LED Status Ring board (F) and place it on the right side of the drive using the temporary placement holes. Refer to the manual packaged with the drive for details on removing the LED Status Ring board.

**NOTICE:** Do not remove the LED Status Ring board cable connector. Failure to comply could cause erroneous operation and damage the drive.

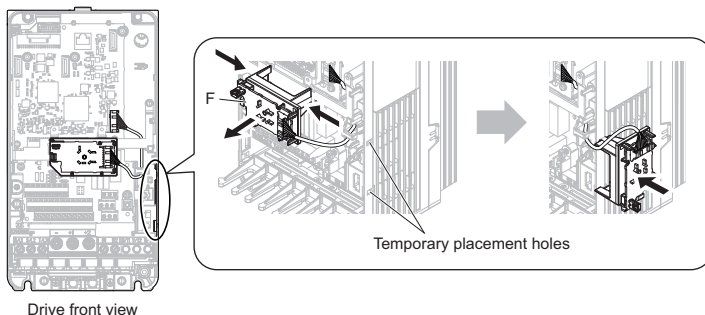

**Figure 14 Remove the LED Status Ring Board**

3. Insert the option card (B) into the CN5-B (H) or CN5-C (I) connector on the drive and fasten it into place using the included screws (C). Tighten both screws to 0.5 to 0.6 N·m (4.4 to 5.3 in·lb).  
Use the CN5-C connector (I) when connecting only one option to the drive; use both CN5-B (H) and CN5-C when connecting two options.

**Note:** Installing the option card on GA700, GA800, CR700, and CH700 drives requires only two screws and does not require a ground wire. The option package ships with three screws and ground wires for installation on other product series. Do not use the ground wire or the extra screw.

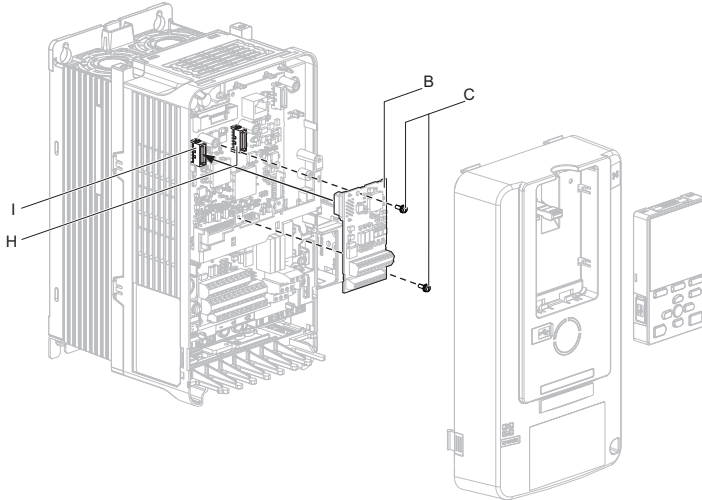

**Figure 15 Insert the Option Card**

4. Prepare the wire ends as shown in [Figure 16](#).

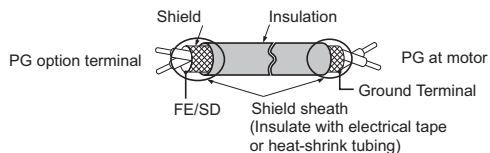

**Figure 16 Prepare Ends of Shielded Cable**

## 5 Installation Procedure

5. Wire the motor PG encoder to the terminal block on the option according to **Figure 17**. Refer to **Figure 21** for the PG-B3 Option and PG Encoder connection diagram. Refer to **Table 9** for a detailed description of the option terminal functions.

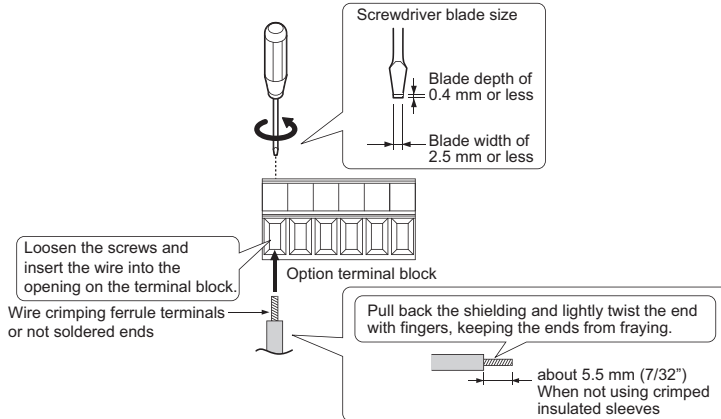
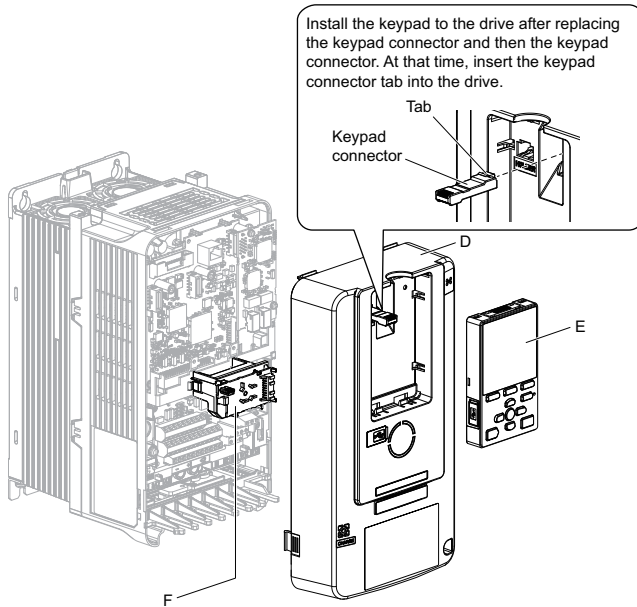

Figure 17 Connect Cable Wiring

Table 4 Parameter Settings and Connections for Different Encoder Types

PG Encoder type	Control Method	Number of PG Encoders	F1-21 Setting	F1-37 Setting
Single-Pulse (A)	V/f w/PG	1	0	N/A
		2	N/A	0
	CLV	1	N/A	N/A
		2	N/A	N/A
Two-Pulse (AB Quadrature)	V/f w/PG	1	1	N/A
		2	N/A	1
	CLV	1	None Required	None Required
		2	None Required	None Required
Two-Pulse with Z Marker	V/f w/PG	1	1	N/A
		2	N/A	1
	CLV	1	None Required	None Required
		2	None Required	None Required

6. Reattach the LED Status Ring board (F) and the front cover of the drive (D) including the keypad (E).

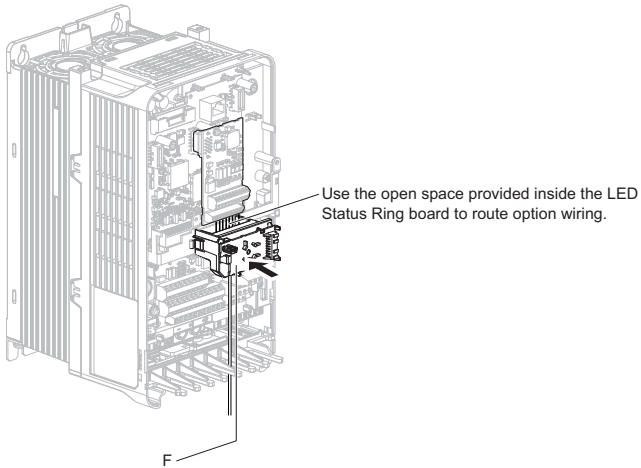

**Figure 18 Replace the LED Status Ring Board, Front Cover, and Keypad**

## 5 Installation Procedure

Reattach the LED Status Ring board (F).  
Use the open space provided inside the LED Status Ring board to route option wiring when using connector CN5-B.

**NOTICE:** Do not pinch cables between the front cover or the LED Status Ring board and the drive. Failure to comply could cause erroneous operation.



7. Connect the PG encoder outputs to the option.
8. Set drive parameters in [Table 10](#) for proper motor rotation.  
The leading pulse determines the motor rotation direction with a two-pulse or three-pulse PG encoder.  
PG encoder signals with leading pulse A are considered to be rotating forward (counter-clockwise when viewing rotation from motor load side).

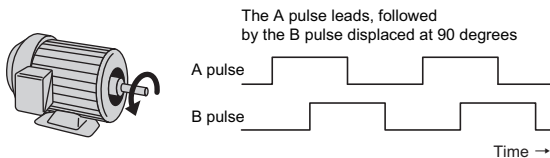

**Figure 19 Displacement of A and B Pulses**

9. Energize the drive and manually rotate the motor to check the rotation direction using monitor U1-05 on the keypad.

**WARNING!** *Sudden Movement Hazard. Lock out the Run circuit to prevent issuing a Run command prior to manually rotating the motor shaft with the drive energized. Failure to comply could cause death or serious injury.*

U1-05 Value	Motor Direction
Negative	Reverse
Positive	Forward

If necessary, either switch the two A channel wires with the two B channel wires on option terminal TB1 as shown in [Figure 20](#) or set F1-05/F1-32 to 1 to change the forward direction.

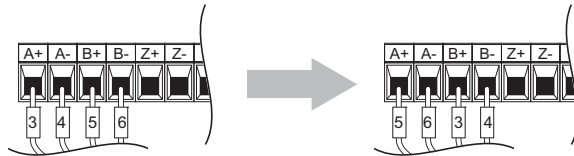

**Figure 20 Switch A Channel and B Channel Wires**

**Note:** Setting A1-03 to 1110, 2220, or 3330 will reset F1-05/F1-32 to factory default. Re-set the parameter to switch direction again.





### ◆ Wire Gauges, Tightening Torques, and Crimp Terminals

#### ■ Wire Gauges and Tightening Torques

Wire gauge and torque specifications are listed in [Table 5](#).

**Table 5 Wire Gauges and Tightening Torques**

Terminal Signal	Screw Size	Tightening Torque N·m (in·lb)	Bare Cable		Crimp Terminals		Wire Type
			Recomm. Gauge mm <sup>2</sup>	Applicable Gauges mm <sup>2</sup>	Applicable Gauges mm <sup>2</sup>	Recomm. Gauge mm <sup>2</sup>	
A+, A-, B+, B-, Z+, Z-, FE, IP, IG	M2	0.22 to 0.25 (1.95 to 2.21)	0.75 (18 AWG)	Stranded wire: 0.25 to 1.0 (24 to 17 AWG)	0.5 (20 AWG)	0.25 to 0.5 (24 to 20 AWG)	Shielded twisted pair, etc.
AO, IG, BO, IG, ZO, IG				Solid wire: 0.25 to 1.5 (24 to 16 AWG)			Shielded cable, etc.

#### ■ Crimp Terminals

Yaskawa recommends using CRIMPFOX 6 by Phoenix Contact or equivalent crimp terminals with the specifications listed in [Table 6](#) for wiring to ensure proper connections.

**Note:** Properly trim wire ends so loose wire ends do not extend from the crimp terminals.

**Table 6 Crimp Terminal Sizes**

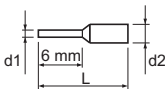
	Wire Gauge mm <sup>2</sup>	Phoenix Contact Model	L mm (in)	d1 mm (in)	d2 mm (in)
	0.25 (24 AWG)	AI 0.25 - 6YE	10.5 (13/32)	0.8 (1/32)	2 (5/64)
	0.34 (22 AWG)	AI 0.34 - 6TQ	10.5 (13/32)	0.8 (1/32)	2 (5/64)
	0.5 (20 AWG)	AI 0.5 - 6WH	14 (9/16)	1.1 (3/64)	2.5 (3/32)

## 5 Installation Procedure

### ■ PG Encoder Cables

Yaskawa recommends using a LMA-□□B-S185Y (complementary output) for cables running between the option and the PG as show in *Figure 22*.

For instructions on wiring the terminal block, refer to *Terminal Functions on page 35*.

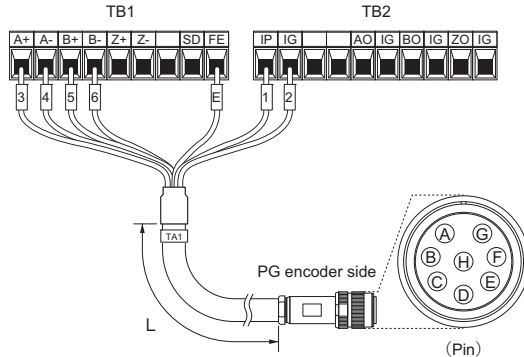

Figure 22 Wiring PG Encoder Cable

Table 7 Connecting the PG Encoder Cable Specification

Option Terminal	PG Encoder Cable		
	Wire	Color	Pin
IP	1	Blue	C
IG	2	White	H
A+	3	Yellow	B
A-	4	White	G
B+	5	Green	A
B-	6	White	F
FE	E	N/A (shield)	D

Table 8 PG Encoder Cable Types

Length	Type	Length	Type
10 m (32 ft)	W5010	50 m (164 ft)	W5050
30 m (98 ft)	W5030	100 m (328 ft)	W5100

### ◆ Terminal Functions

**Table 9 Option Terminal Functions**

Terminal Block	Terminal	Function	Description
TB1	A+	A+ pulse signal input	<ul style="list-style-type: none"> <li>• Pulse signal inputs from the PG.</li> <li>• Signal inputs from complementary and open-collector outputs</li> <li>• Signal level H level: 8 to 12 V L level: 2.0 V or less</li> </ul>
	A-	A- inverse pulse input	
	B+	B+ pulse signal input	
	B-	B- inverse pulse input	
	Z+	Z+ pulse signal input	
	Z-	Z- inverse pulse input	
	SD	NC pin (open)	For use when cables shields should not be grounded
FE	Ground	Used for grounding shielded lines	
TB2	IP	PG power supply	<ul style="list-style-type: none"> <li>• Output voltage: 12.0 V ± 5%</li> <li>• Max output current: 200 mA &lt;I&gt;</li> </ul>
	IG	PG power supply common	
	AO	A pulse monitor signal	<ul style="list-style-type: none"> <li>• Outputs the monitor signal for the A, B, and Z pulses from the PG speed control card</li> <li>• For open collector outputs from the option</li> <li>• Max voltage: 24 V</li> <li>• Max current: 30 mA</li> </ul>
	BO	B pulse monitor signal	
	ZO	Z pulse monitor signal	
	IG	Monitor signal common	

<I> A separate UL-listed class 2 power supply is necessary when the PG requires more than 200 mA to operate.

# 6 Related Parameters

The parameters in *Table 10* set the drive for operation with the option. Set parameters as needed. Refer to the manual packaged with the drive for details on setting parameters.

**Note:** Hex.: MEMOBUS addresses used to change parameters over network communication are represented in hexadecimal numbers.

**Table 10 Related Parameters**

No. (Hex.)	Name	Description	Control Method	Values
A1-02 (102)	Control Method Selection	0: V/f Control 1: Closed Loop V/f Control 2: Open Loop Vector Control 3: Closed Loop Vector Control 4: Advanced Open Loop Vector Control 5: PM Open Loop Vector Control 6: PM Advanced Open Loop Vector 7: PM Closed Loop Vector Control 8 : EZ Open Loop Vector Control	All Modes	Default: </> Range: </>
F1-01 (380) </> </>	PG 1 Pulses per Revolution	Sets the number of pulses per motor revolution.	V/f w/ PG CLV AOLV	Default: </> Min: </> Max: </>
F1-02 (381)	PG Feedback Loss Selection	Selects the stopping method after PG disconnect (PGo). 0: Ramp to stop 1: Coast to stop 2: Fast Stop (Use C1-09) 3: Alarm only 4: No alarm display <b>NOTICE:</b> Use settings 3 and 4 under special circumstances only. Failure to comply could damage the motor and connected machinery.	V/f w/ PG CLV AOLV	Default: 1 Range: </>
F1-03 (382)	Operation Select at Overspeed	Selects the stopping method after detecting overspeed (oS). 0: Ramp to stop 1: Coast to stop 2: Fast Stop (Use C1-09) 3: Alarm only <b>NOTICE:</b> Use setting 3 under special circumstances only. Failure to comply could damage the motor and connected machinery.	V/f w/ PG CLV AOLV	Default: 1 Range: 0 to 3

## 6 Related Parameters

No. (Hex.)	Name	Description	Control Method	Values
F1-04 (383)	Operation Select at Overspeed	0: Ramp to stop 1: Coast to stop 2: Fast Stop (Use C1-09) 3: Alarm only <b>NOTICE:</b> Use setting 3 under special circumstances only. Failure to comply could damage the motor and connected machinery.	V/f w/ PG CLV AOLV	Default: <f> Range: 0 to 3
F1-05 (384) <>	PG 1 Rotation Selection	0: Pulse A leads 1: Pulse B leads	V/f w/ PG CLV AOLV	Default: <f> Range: 0, 1
F1-06 (385) <>	PG 1 Division Rate for Pulse Mon	Sets the division ratio for PG encoder pulse output. Set as a three-digit number: x is the first digit, y is the second digit, and z is the third digit: $\text{Ratio} = \frac{(1+x)}{yz}$ When only the A pulse is read, this ratio is disabled and pulses are set as 1/32 : 1.	V/f w/ PG CLV AOLV	Default: 1 Min: 1 Max: 132
F1-08 (387)	Overspeed Detection Level	Sets the level for detecting overspeed (oS) as a percentage of the maximum output frequency.	V/f w/ PG CLV AOLV	Default: 115 Min: 0 Max: 120
F1-09 (388)	Overspeed Detection Delay Time	Sets the time required for the motor to exceed the level set in F1-08 to trigger a fault (oS).	V/f w/ PG CLV AOLV	Default: <f> Min: 0.0 Max: 2.0
F1-10 (389)	Speed Deviation Detection Level	Sets the degree of speed deviation to trigger a dEv fault. Set as a percentage of the maximum output frequency.	V/f w/ PG CLV AOLV	Default: 10 Min: 0 Max: 50
F1-11 (38A)	Speed Deviation Detect Delay Time	Sets the time required for a speed deviation situation to trigger a fault.	V/f w/ PG CLV AOLV	Default: 0.5 Min: 0.0 Max: 10.0
F1-12 (38B) <> <>	PG 1 Gear Teeth 1	Number of gear teeth between the PG and motor. $\frac{\text{Pulses} \times 60}{\text{F1-01}} \times \frac{\text{F1-13 (load side)}}{\text{F1-12 (motor side)}}$ A gear ratio of 1 will be used if any of these parameters is set to 0.	V/f w/ PG	Default: 0 Min: 0 Max: 1000
F1-13 (38C) <> <>	PG 1 Gear Teeth 2			
F1-14 (38D)	PG Open-Circuit Detection Time	Sets the time in seconds for PG encoder disconnect to be detected. <b>Note:</b> An ov or oC error may occur depending on motor speed and load conditions.	V/f w/ PG CLV AOLV	Default: 2.0 Min: 0.0 Max: 10.0
F1-21 (38C) <>	PG 1 Signal Selection	0: A pulse detection 1: AB pulse detection	V/f w/ PG	Default: 0 Range: 0, 1

## 6 Related Parameters

No. (Hex.)	Name	Description	Control Method	Values
F1-30 (3AA) <6>	Motor 2 PG Option Port Selection	Selects the PG option connector for motor 2. 0: CN5-C 1: CN5-B	V/f w/ PG CLV	Default: 1 Range: 0, 1
F1-31 (3B0) <2> <7>	PG 2 Pulses per Revolution	Sets the number encoder number of pulses per revolution.	V/f w/ PG CLV	Default: 1024 Min: 0 Max: 60000
F1-32 (3B1) <7>	PG 2 Rotation	0: Pulse A leads 1: Pulse B leads	V/f w/ PG CLV	Default: 0 Range: 0, 1
F1-33 (3B2) <5> <7>	PG 2 Gear Teeth 1	Sets the number of gear teeth between the PG and motor.	V/f w/ PG	Default: 0 Min: 0 Max: 1000
F1-34 (3B3) <5> <7>	PG 2 Gear Teeth 2	$\frac{\text{Pulses} \times 60}{\text{F1-31}} \times \frac{\text{F1-33 (load side)}}{\text{F1-34 (motor side)}}$ A gear ratio of 1 will be used if any of these parameters is set to 0.		
F1-35 (3BE) <7>	PG 2 Division Rate for Pulse Mon	Sets the division ratio for PG encoder pulse output. Set as a three-digit number where x is the first digit, y is the second digit, and z is the third digit: $\text{Ratio} = \frac{(1 + x)}{yz}$ When only the A pulse is read, this ratio is disabled and pulses are set as 1/32 : 1.	V/f w/ PG CLV	Default: 1 Min: 1 Max: 132
F1-37 (3BD) <7>	PG 2 Signal Selection	0: A pulse detection 1: AB pulse detection	V/f w/ PG	Default: 0 Range: 0, 1

<1> Varies by drive model.

<2> Use the following formula to calculate the number of output pulses for the PG encoder:

$$f_{PG}(\text{Hz}) = \frac{\text{Motor speed at maximum frequency output (min}^{-1}\text{)}}{60} \times \text{PG rating (p/rev)}$$

<3> Available only when using connector CN5-C.

<4> Dependent upon A1-02.

<5> Available only in V/f w/PG.

<6> A second PG encoder (PG 2) may not be possible depending on the product series. Refer to the drive Technical Manual for the drive in your application.

<7> Available only when using connector CN5-B.

## 7 Troubleshooting

### ◆ Drive-Side Error Codes

*Table 11* lists the various fault codes related to the option and pulse generator. Refer to the drive Technical Manual for further details on fault codes.

Confirm the following items upon receiving an error notification on the drive keypad:

1. Correct and secure cable connections including ground wiring.
2. Proper option installation.
3. No momentary power loss occurred.

**Table 11 Fault Displays, Causes, and Possible Solutions**

Keypad Display		Fault Name
dEv	dEv	Speed Deviation (for Control Mode with PG)
		The deviation between the speed reference and speed feedback is greater than the setting in F1-10 for longer than the time set to F1-11.
Cause		Possible Solution
The load is too heavy.		Reduce the load.
The acceleration and deceleration times are set too short.		Increase the acceleration and deceleration times (C1-01 through C1-08).
The load is locked up.		Check the machine.
Parameters are set inappropriately.		Check F1-10 and F1-11 settings.
Motor brake is engaged.		Ensure the motor brake releases properly.
Keypad Display		Fault Name
dv1	dv1	Z Channel Pulse Fault Detection
		The motor turned one full rotation while failing to detect the Z channel pulse.
Cause		Possible Solution
The PG option or PG encoder are damaged.		1. Confirm that the PG encoder is properly connected and all shielded lines are properly grounded.
The PG encoder is not wired properly or is disconnected.		2. Cycle power. Replace the PG option card or the PG encoder if the problem continues after cycling power.

## 7 Troubleshooting

Keypad Display		Fault Name
dv2	dv2	Z Channel Pulse Noise Fault Detection
Cause		Possible Solution
PG encoder cable electrical interference.		Separate the PG encoder cable wiring from the source of the interference (e.g., drive output wiring).
The PG encoder is not wired properly or is disconnected.		Make sure the PG encoder is properly wired or is not disconnected and all shielded lines are properly grounded.
The PG option or PG encoder are damaged.		<ol style="list-style-type: none"> <li>1. Confirm that the PG encoder is properly connected and all shielded lines are properly grounded.</li> <li>2. Cycle power. Replace the PG option card or the PG encoder if the problem continues after cycling power.</li> </ol>
Keypad Display		Fault Name
oFA00	oFA00	Non-compatible option is connected to drive port CN5-A.
Cause		Possible Solution
Non-compatible option is connected to drive port CN5-A.		Use only compatible options. The PG option cannot be connected to CN5-A. For other options, refer to the Installation Manual for that option.
Keypad Display		Fault Name
oFb00	oFb00	Non-compatible option is connected to drive port CN5-B.
Cause		Possible Solution
Non-compatible option is connected to drive port CN5-B.		Connect the option to the correct option port. <b>Note:</b> When connecting DO-A3, AO-A3, PG-B3, or PG-X3, use CN5-B. When connecting only one PG option, use CN5-C.
Keypad Display		Fault Name
oFb01	oFb01	Option Connection Error at drive port CN5-B
Cause		Possible Solution
Option in drive port CN5-B was changed during run.		De-energize the drive and plug the option into the drive according to Installation Procedure on Page 12.
Keypad Display		Fault Name
oFC01	oFC01	Option Connection Error at drive port CN5-C
Cause		Possible Solution
Option at drive port CN5-C was changed during run.		De-energize the drive and plug the option into the drive according to Installation Procedure on Page 12.



Keypad Display		Fault Name
oS	oS	Overspeed
		The motor speed feedback exceeded the F1-08 setting.
<b>Cause</b>		<b>Possible Solution</b>
Overshoot is occurring.		<ul style="list-style-type: none"> <li>• Increase the settings for C5-01 (Speed Control Proportional Gain 1) and reduce C5-02 (Speed Control Integral Time 1).</li> <li>• Adjust the input signal using parameters H6-02 through H6-05.</li> <li>• Enable Feed Forward Control and perform Inertia Auto-Tuning in CLV.</li> </ul>
Incorrect speed feedback scaling when terminal RP is used as speed feedback input in V/f control.		Set H6-02 to the value of the speed feedback signal frequency when the motor runs at the maximum speed.
Inappropriate parameter settings.		Check the setting for the overspeed detection level and the overspeed detection time (F1-08 and F1-09).
Keypad Display		Fault Name
PGo	PGo	PG Encoder Disconnected
		The drive has not received a PG encoder pulse for longer than the time set in F1-14.
<b>Cause</b>		<b>Possible Solution</b>
The PG encoder is disconnected or is not wired properly.		Make sure the PG encoder is properly wired or is not disconnected.
PG encoder does not have enough power.		Confirm that the correct power supply is properly connected to the PG encoder.
Motor brake is engaged.		Ensure the brake releases properly.

**Table 12 Operation Error Displays, Causes, and Possible Solutions**

Keypad Display		Fault Name
oPE06	oPE06	Control Method Selection Error
		Correct the setting for the control method.
<b>Cause</b>		<b>Possible Solution</b>
Control method requires installing a PG option, but no PG option is installed (A1-02 = 1, 3, or 7).		<ul style="list-style-type: none"> <li>• Connect a PG option.</li> <li>• Correct the value set to A1-02.</li> </ul>



## 8 European Standards



Figure 25 CE Mark

The CE mark indicates compliance with European safety and environmental regulations. It is required for engaging in business and commerce in Europe.

European standards include the Machinery Directive for machine manufacturers, the Low Voltage Directive for electronics manufacturers, and the EMC guidelines for controlling noise.

This option displays the CE mark based on the EMC guidelines.

### **EMC Guidelines:** 2014/30/EU

Drives used in combination with this option and devices used in combination with the drive must also be CE certified and display the CE mark. When using drives displaying the CE mark in combination with other devices, it is ultimately the responsibility of the user to ensure compliance with CE standards. Verify that conditions meet European standards after setting up the device.

---

### ◆ **EMC Guidelines Compliance**

This option is tested according to European standards EN 61800-3:2004/A1:2012 and complies with EMC guidelines. The CE marking is declared based on the harmonized standards.

### ■ **EMC Guidelines Installation Conditions**

Verify the following installation conditions to ensure that other devices and machinery used in combination with this option also comply with EMC guidelines:

1. Use dedicated shield cable for the option and external device (encoder, I/O device, master), or run the wiring through a metal conduit.
2. Keep wiring as short as possible and ground the largest possible surface area of the shield to the metal panel according to [Figure 27](#).

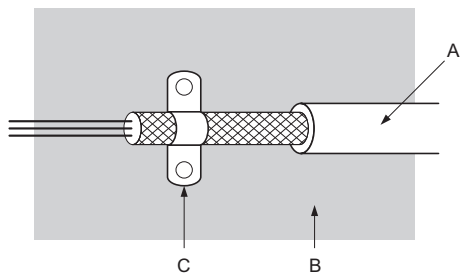

- A – Braided shield cable
- B – Metal panel
- C – Cable clamp (conductive)

Figure 26 Ground Area

■ **Option Installation for CE Compliance: Models PG-□□,DI-□□,DO-□□, AI-□□,AO-,SI-□□**

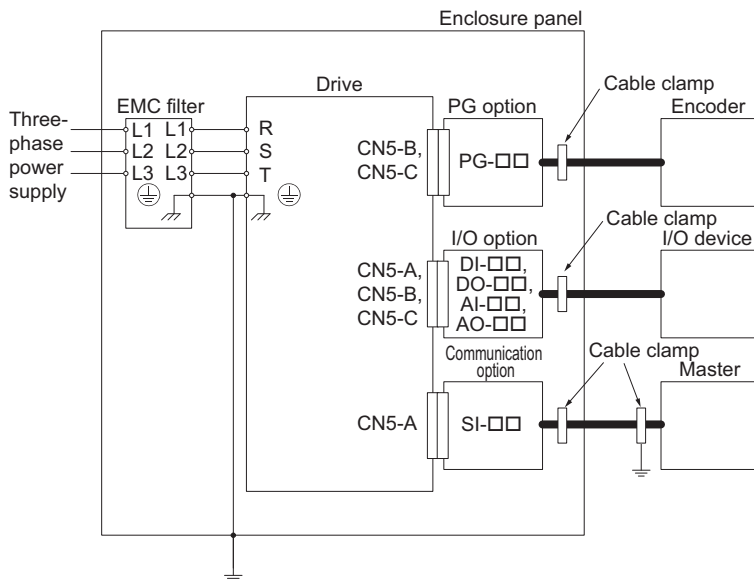

Figure 27 Option Installation for CE Compliance

# 9 Specifications

**Table 13 Option Specifications**

Items	Description
<b>Model</b>	PG-B3
<b>Compatible Pulse Generators</b>	Complementary, Open-collector Single-pulse (A pulse), two-pulse (A, B pulse) or three-pulse (A, B, Z pulse) H level: 8 to 12 V L level: 2.0 V max.
<b>PG Encoder Wiring Length</b>	Complementary: 100 m (328 ft) maximum Open-collector: 50 m (164 ft) maximum
<b>PG Encoder Power Supply</b>	Output voltage: 12 V $\pm$ 5% Max. Output Current: 200 mA
<b>Compatible Control Modes</b>	V/f w/PG, CLV, AOLV
<b>Maximum Input Frequency</b>	50 kHz
<b>Pulse Monitor Output</b>	Monitor for A, B, and Z pulse output: 24 V max, 30 mA Open-collector output
<b>Pulse Monitor Wiring Length</b>	30 m (98 ft) maximum
<b>PG Encoder Disconnect Detection</b>	Software detection
<b>Ambient Temperature</b>	-10°C to 50°C (14°F to 122°F)
<b>Humidity</b>	95% RH or lower with no condensation
<b>Storage Temperature</b>	-20°C to 60°C (-4°F to 140°F) allowed for short-term transport of the product
<b>Area of Use</b>	Indoors and free from: <ul style="list-style-type: none"> <li>• Oil mist, corrosive gas, flammable gas, and dust</li> <li>• Radioactive materials or flammable materials, including wood</li> <li>• Harmful gas or fluids</li> <li>• Salt</li> <li>• Direct sunlight</li> <li>• Falling foreign objects</li> </ul>
<b>Altitude</b>	1000 m (3280 ft) or lower

---

## ◆ Revision History

Revision dates and manual numbers appear on the bottom of the back cover.

MANUAL NO.

TOBP C730600 75B <1>

Revision number

Published in Japan February 2017

Date of publication

Date of Publication	Rev. No	Section	Revised Content
September 2018	<4>	All	Addition: Applicable product series Revision: Reviewed and corrected entire documentation.
		Back cover	Revision: Address
August 2018	<3>	–	Address in Japanese version.
September 2017	<2>	Back cover	Revision: Address
February 2017	<1>	All	Addition: Applicable product series Revision: Reviewed and corrected entire documentation.
		Back cover	Revision: Address
April 2016	–	–	First edition

# YASKAWA AC Drive Option Complementary Type PG Installation Manual

---

## **DRIVE CENTER (INVERTER PLANT)**

2-13-1, Nishimiyaichi, Yukuhashi, Fukuoka, 824-8511, Japan  
Phone: +81-930-25-2549 Fax: +81-930-25-3431  
<http://www.yaskawa.co.jp>

## **YASKAWA ELECTRIC CORPORATION**

New Pier Takeshiba South Tower, 1-16-1, Kaigan, Minato-ku, Tokyo, 105-6891, Japan  
Phone: +81-3-5402-4502 Fax: +81-3-5402-4580  
<http://www.yaskawa.co.jp>

## **YASKAWA AMERICA, INC.**

2121, Norman Drive South, Waukegan, IL 60085, U.S.A.  
Phone: +1-800-YASKAWA (927-5292) or +1-847-887-7000 Fax: +1-847-887-7310  
<http://www.yaskawa.com>

## **YASKAWA ELÉTRICO DO BRASIL LTDA.**

777, Avenida Piraporinha, Diadema, São Paulo, 09950-000, Brasil  
Phone: +55-11-3585-1100 Fax: +55-11-3585-1187  
<http://www.yaskawa.com.br>

## **YASKAWA EUROPE GmbH**

Hauptstraße 185, 65760 Eschborn, Germany  
Phone: +49-6196-569-300 Fax: +49-6196-569-398  
<http://www.yaskawa.eu.com> E-mail: [info@yaskawa.eu.com](mailto:info@yaskawa.eu.com)

## **YASKAWA ELECTRIC KOREA CORPORATION**

35F, Three IFC, 10 Gukjegeumyung-ro, Yeongdeungpo-gu, Seoul, 07326, Korea  
Phone: +82-2-784-7944 Fax: +82-2-784-9495  
<http://www.yaskawa.co.kr>

## **YASKAWA ELECTRIC (SINGAPORE) PTE. LTD.**

151, Lorong Chuan, #04-02A, New Tech Park, 556741, Singapore  
Phone: +65-6282-3003 Fax: +65-6289-3003  
<http://www.yaskawa.com.sg>

## **YASKAWA ELECTRIC (THAILAND) CO., LTD.**

59, 1st-5th Floor, Flourish Building, Soi Ratchadapisek 18, Ratchadapisek Road, Huaykwang, Bangkok, 10310, Thailand  
Phone: +66-2-017-0099 Fax: +66-2-017-0799  
<http://www.yaskawa.co.th>

## **YASKAWA ELECTRIC (CHINA) CO., LTD.**

22F Link Square 1, No.222, Hubin Road, Shanghai, 200021, China  
Phone: +86-21-5385-2200 Fax: +86-21-5385-3299  
<http://www.yaskawa.com.cn>

## **YASKAWA ELECTRIC (CHINA) CO., LTD. BEIJING OFFICE**

Room 1011, Tower W3 Oriental Plaza, No. 1, East Chang An Ave.,  
Dong Cheng District, Beijing, 100738, China  
Phone: +86-10-8518-4086 Fax: +86-10-8518-4082

## **YASKAWA ELECTRIC TAIWAN CORPORATION**

12F, No.207, Sec. 3, Beishin Rd., Shindian Dist., New Taipei City 23143, Taiwan  
Phone: +886-2-8913-1333 Fax: +886-2-8913-1513 or +886-2-8913-1519  
<http://www.yaskawa.com.tw>

## **YASKAWA INDIA PRIVATE LIMITED**

#17/A, Electronics City, Hosur Road, Bangalore, 560 100 (Karnataka), India  
Phone: +91-80-4244-1900 Fax: +91-80-4244-1901  
<http://www.yaskawaindia.in>

---

# YASKAWA

**YASKAWA ELECTRIC CORPORATION**

In the event that the end user of this product is to be the military and said product is to be employed in any weapons systems or the manufacture thereof, the export will fall under the relevant regulations as stipulated in the Foreign Exchange and Foreign Trade Regulations. Therefore, be sure to follow all procedures and submit all relevant documentation according to any and all rules, regulations and laws that may apply.

Specifications are subject to change without notice for ongoing product modifications and improvements.

© 2016 YASKAWA ELECTRIC CORPORATION

MANUAL NO.

TOBP C730600 75C <4>-0

Published in Japan September 2018  
18-8-19